



Network for Cost-effective
Technologies in Water Supply

Technology Selection - and Buyer's Guide for Public Domain Handpumps for Drinking Water



*skat*_foundation

Resource Centre for
Development

Karl Erpf, HTN
November 2002

Vadianstrasse 42
CH-9000 St.Gallen, Switzerland
phone: +41 (0)71 228 54 54
fax: +41 (0)71 228 54 55
email: karl.erpf@skat.ch
web: www.skat.ch

skat_foundation

Resource Centre for
Development

**Buyer's - and technology selection Guide
for**

**Public Domain Handpumps
for Drinking Water**

Introduction

This document contains information on the Public Domain Handpumps available on the market and is intended to give assistance to all those, who are evaluating or intending to procure handpumps.

Included is condensed information on the different handpump types as there are:

- a) Extracts of the specifications
- b) Existing options
- c) Information on supporting documents

Included in this document are the following handpump types:

Suction Pumps for Shallow Wells,
No.6 Handpump, India

Direct Action Pumps for Shallow and Medium Wells,
Malda Pump, Malawi
Maya-Yaku Pump, Bolivia
Tara Pump, India

Rotary Pumps for Shallow, Medium and Deep Wells,
Rope Pump, Madagascar
Rope Pump, Nicaragua

Lever operated Pumps for Medium and Deep Wells,
Jibon Pump, Bangladesh
Walimi Pump, Tanzania
India Mark II Pump
India Mark III Pump
U3M Pump, Uganda
Afridev Handpump
Bush Pump, Zimbabwe

Lever operated Pumps for Extra Deep Wells,
India Mark II Extra Deep Well
Afridev Deep Well Pump with Bottom Support

This SKAT-HTN document is accessible in the following forms:

- a) ordered as a "Hard copy"
- b) ordered as a Compact Disk (CD)
- c) downloaded directly from the SKAT-HTN Homepage

Contents

Overview on the operation depths of various Public Domain Handpumps	4
1.) Suction Pumps for Shallow Wells	
Extracts of:	
No.6 Handpump, India	5
2.) Direct Action Pumps for Shallow and Medium Wells	
Extracts of:	
Malda Pump, Malawi	8
Maya-Yaku Pump, Bolivia	13
Tara Pump, India	17
3.) Rotary Pumps for Shallow, Medium and Deep Wells	
Extracts of:	
Rope Pump, Madagascar	22
Rope Pump, Nicaragua	26
4.) Lever operated Pumps for Medium and Deep Wells	
Extracts of:	
Jibon Pump, Bangladesh	27
Walimi Pump, Tanzania	31
India Mark II Pump	36
India Mark III Pump	41
U3M Pump, Uganda	46
Afridev Handpump	52
Bush Pump, Zimbabwe	58
5.) Lever operated Pumps for Extra Deep Wells	
Extracts of:	
India Mark II Extra Deep Well	63
Afridev Deep Well Pump with Bottom Support	66
Appendix I	70
Order Form for Publications	
Appendix II	73
Addresses for ordering Publications	

Operation depths of the various Public Domain handpump types

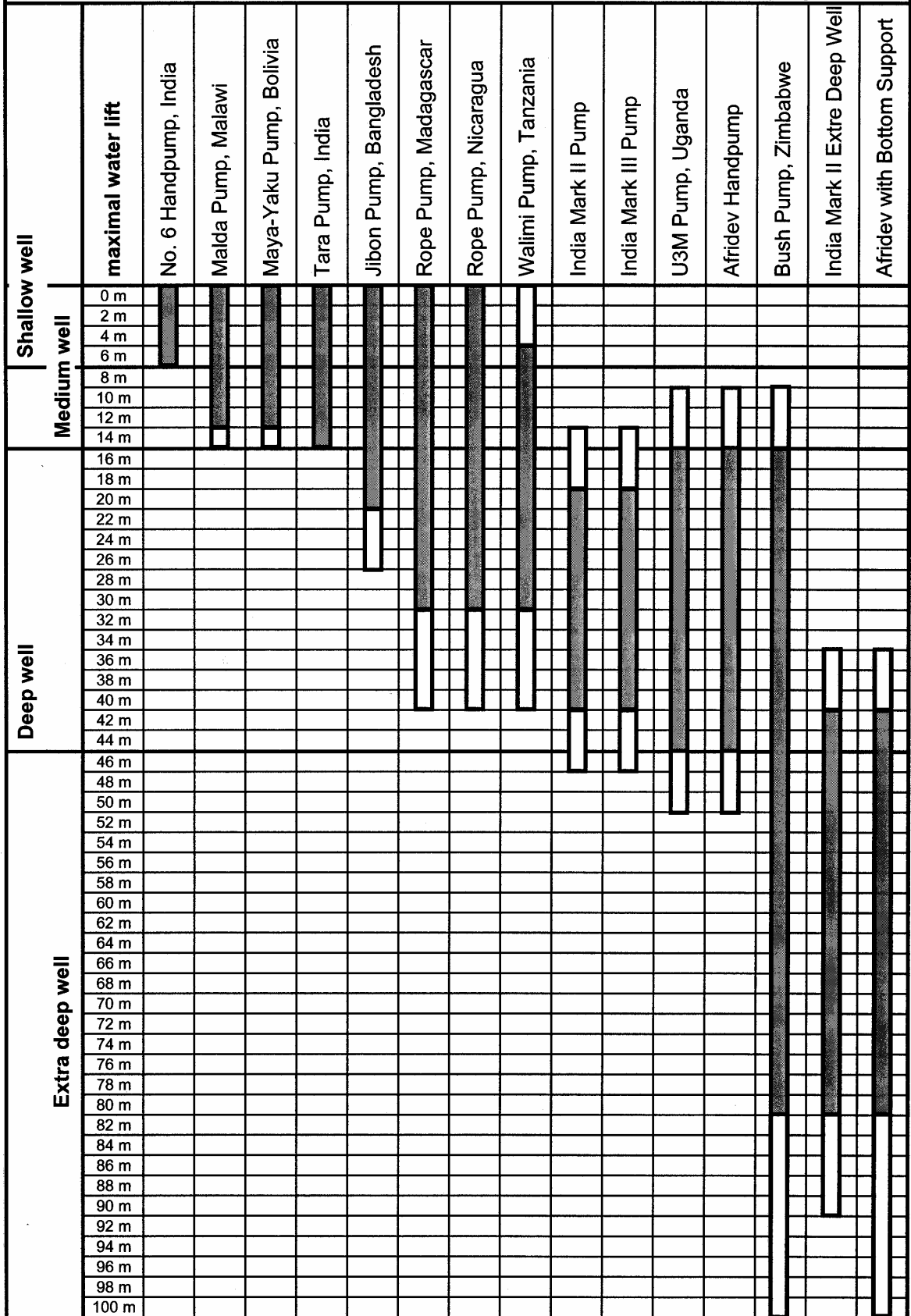

1.) Suction Pumps for Shallow Wells

No. 6 Handpump, India

India Standard Document IS

recommended use between depths of 0 to 6 m.

Supporting documents:

Handpump Specification, available from BIS (see address in Appendix II)

Revision 0-2002

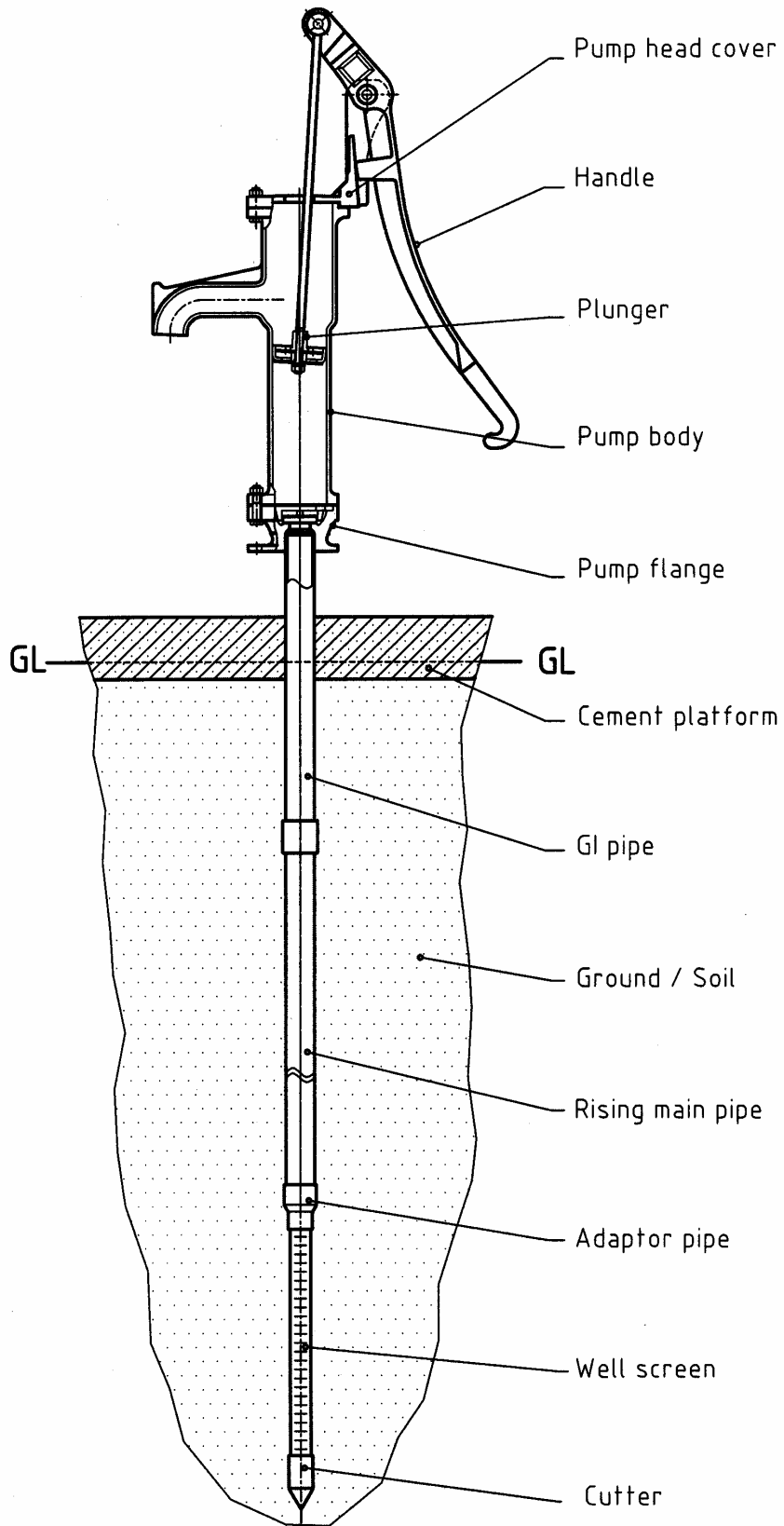

HTN	No.6 Pump	Scale:	1 : 10	Drawn by:	K. Erpf	09.09.02
	Pump assembly			Checked by:		
	International Handpump Specification			Released by:		
						D9169

No. 6 Pump, India

Pump head type	Cast-iron Pump head cover and Handle
-----------------------	--------------------------------------

Pump stand type	Cast-iron Pump body with Base plate
------------------------	-------------------------------------

Rising main arrangement	GI pipe (1.5 m long) Rising main and Robo-screen of PVC-U
--------------------------------	--

Cylinder arrangement	Inside Pump body (suction pump)
-----------------------------	---------------------------------

Pumprod arrangement	MS- Pumprod with PVC-U Cup seal
----------------------------	---------------------------------

Abbreviations:

GI Galvanized Iron
MS Mild Steel
PVC-U Polyvinyl Chloride (unplastcized)

2.) Direct Action Pumps for Shallow and Medium Wells

Malda Pump, Malawi

SKAT-HTN Document (Revision 1-2000)

recommended use between depths of 0 to 14 m.

Supporting documents:

Handpump Specification

Installation and Maintenance Manual

Revision 1-2000

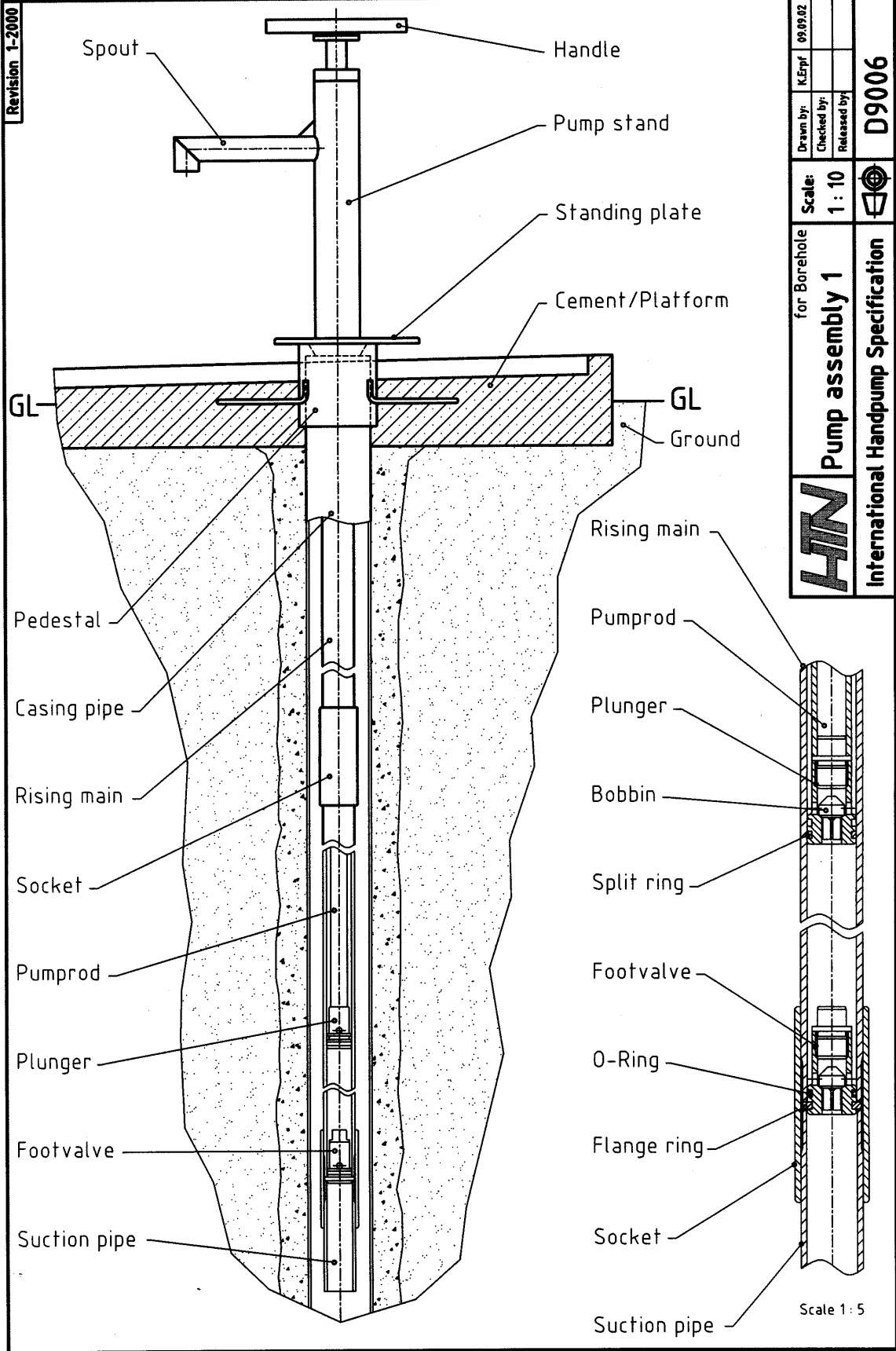

Drawn by:	K.Eprl	09/09/02
Checked by:		
Released by:		
Scale:	1 : 10	
for Borehole		
HTN	Pump assembly 1	D9006
International Handpump Specification		

Malda Pump, Malawi

List of options available for this pump type.

Options	A	B
Pump stand type	Pump stand with Handle & Pedestal: drawing No. A5002	Pump stand with Handle & ISO Flange: drawing No. D9098
Rising main arrangement	HDPE- Rising main with threaded Sockets	---
Cylinder arrangement	Cylinder with Plunger & Footvalve in HDPE drawing No. A5004	---
Pumprod arrangement	Threaded Pumprod pipes in HDPE drawing No. A5006	---

Abbreviations:

ISO International Standards Organisation
 HDPE High Density Poly Ethylene

Example:

Possible composition of a selected Malda Pump:

Pump stand type	B
Rising main arrangement	A
Cylinder arrangement	A
Pumprod arrangement	A

For more clarification see the following 2 pages!

Pump stand assembly

(approx. scale = 1 : 6)

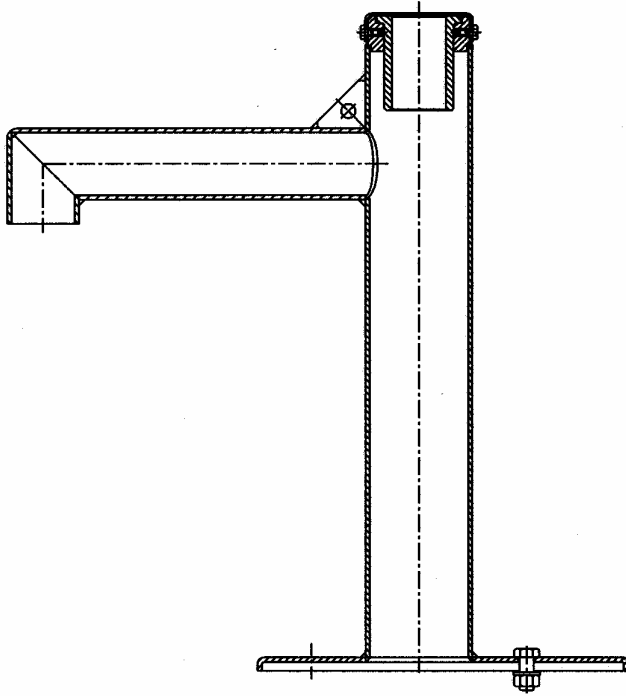

Handle assembly

(approx. scale = 1 : 6)

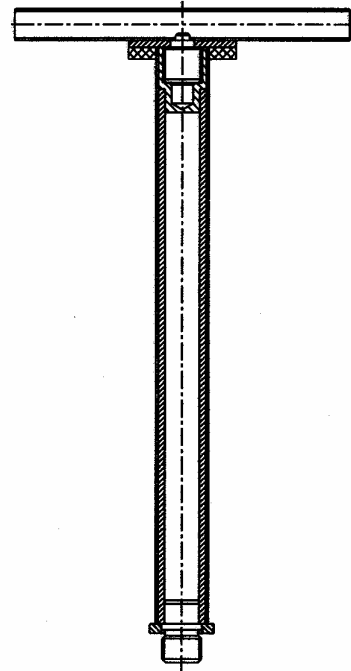

Pedestal assemblies

(approx. scale = 1 : 6)

A

Options:

B *

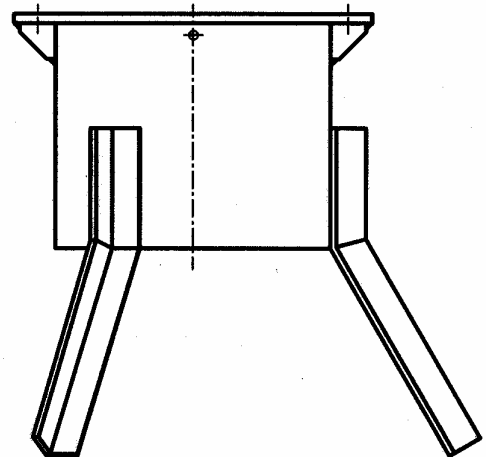
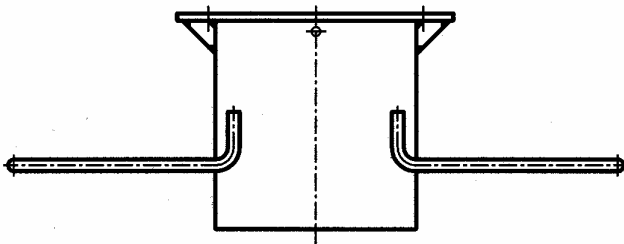
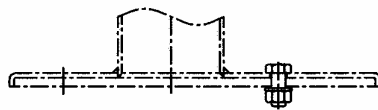

For use on Dugwells and Boreholes

* If Option B is chosen, a different Standing plate is required

Rising main arrangement

(approx. scale = 1 : 5)

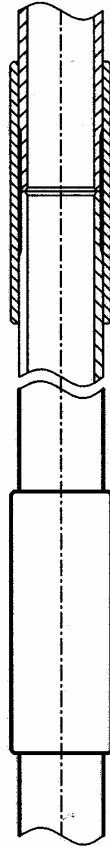

HDPE Riser pipes
are available in
1 m length
2 m length
3 m length

Cylinder arrangement

(approx. scale = 1 : 5)

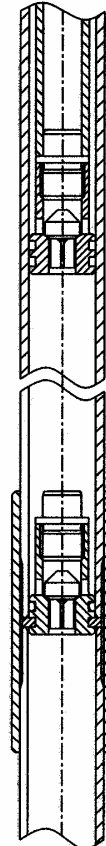

Pumprod arrangement

(approx. scale = 1 : 5)

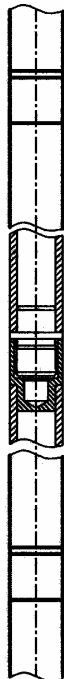

HDPE Pumprods
are available in
0.5 m length
2 m length
3 m length

Maya-Yaku Pump, Bolivia

SKAT-HTN Document (Edition 1993)

recommended use between depths of 0 to 14 m.

Supporting documents:

Handpump Specification (Spanish version only)

REV. 0-1993

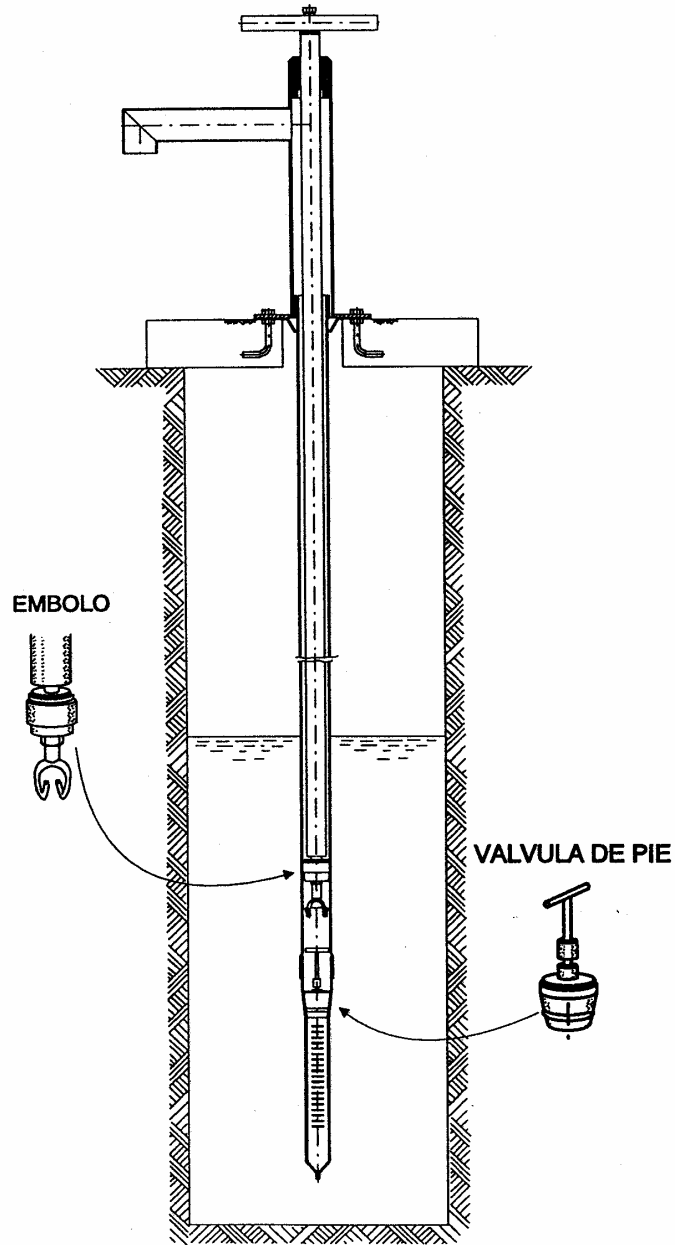

NO.		ESPECIFICACION		MATERIAL	OBSERVACION
REV. NO.	NOMBRE	FECHA	TREFF AG	ESC.	BOMBA DE ACCION DIRECTA (MAYA - YAKU) SKAT
	RU	JULIO 1993		15	
					PIEZA :BOMBA DE ACCION DIRECTA 1.00

Maya-Yaku Pump, Bolivia

Pump stand type	Pump stand with Handle & Pedestal
------------------------	-----------------------------------

Rising main arrangement	PVC-U Rising main with "Bell-ends"
--------------------------------	------------------------------------

Cylinder arrangement	PVC-U Cylinder PVC-U / SS Plunger and Footvalve
-----------------------------	---

Pumprod arrangement	PVC-U Pumprod pipes with union connectors
----------------------------	---

Abbreviations:

PVC-U Polyvinyl Chloride (unplastcized)
SS Stainless Steel

Note: The Maya-Yaku Pump should only be used in dug wells or lined boreholes.

For more clarification see the following page!

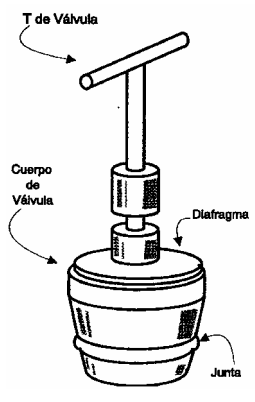
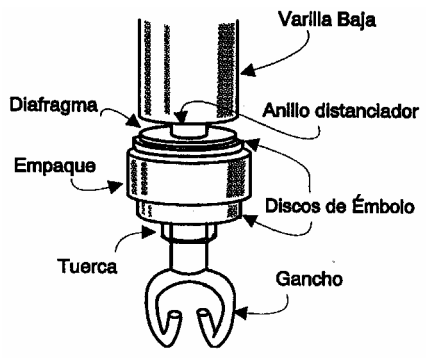
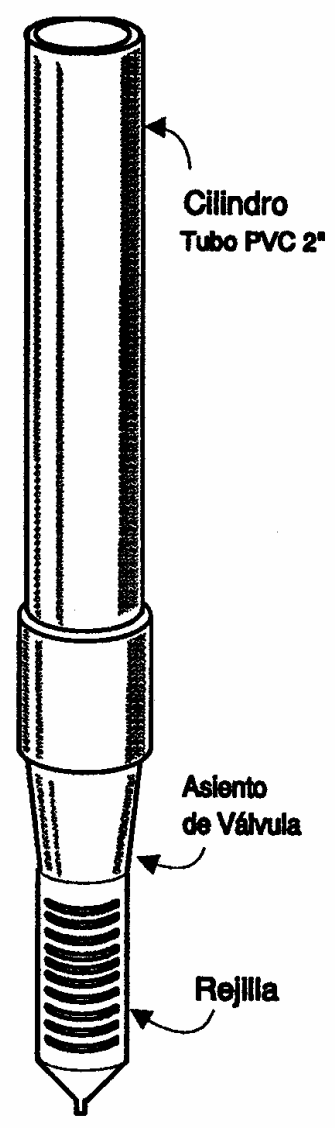
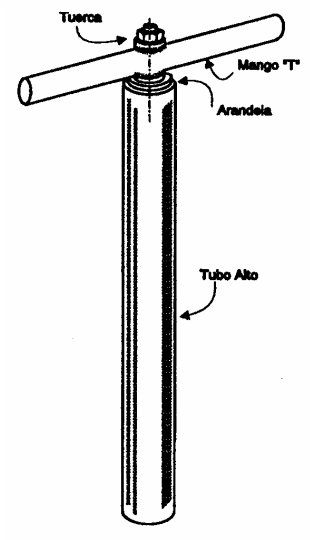
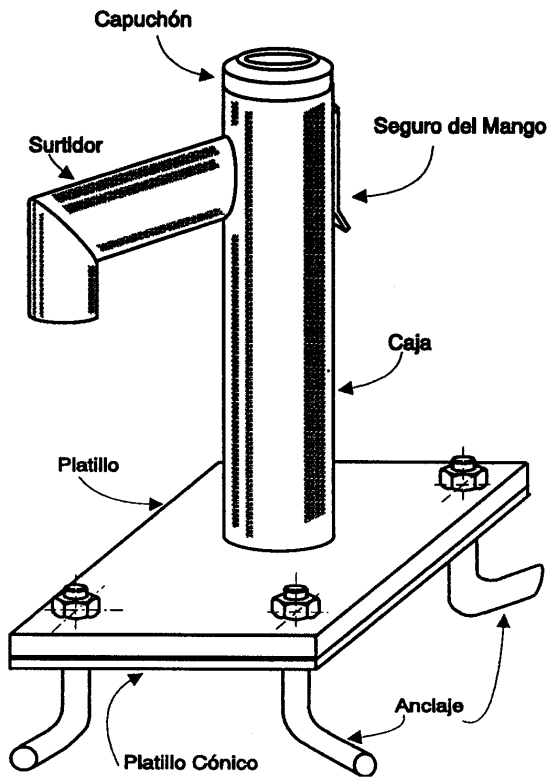

Tara Pump, India

India Standard Document, IS 14106 : 1996

recommended use between depths of 0 to 14 m.

Supporting documents:

Handpump Specification, available from BIS (see address in Appendix II)

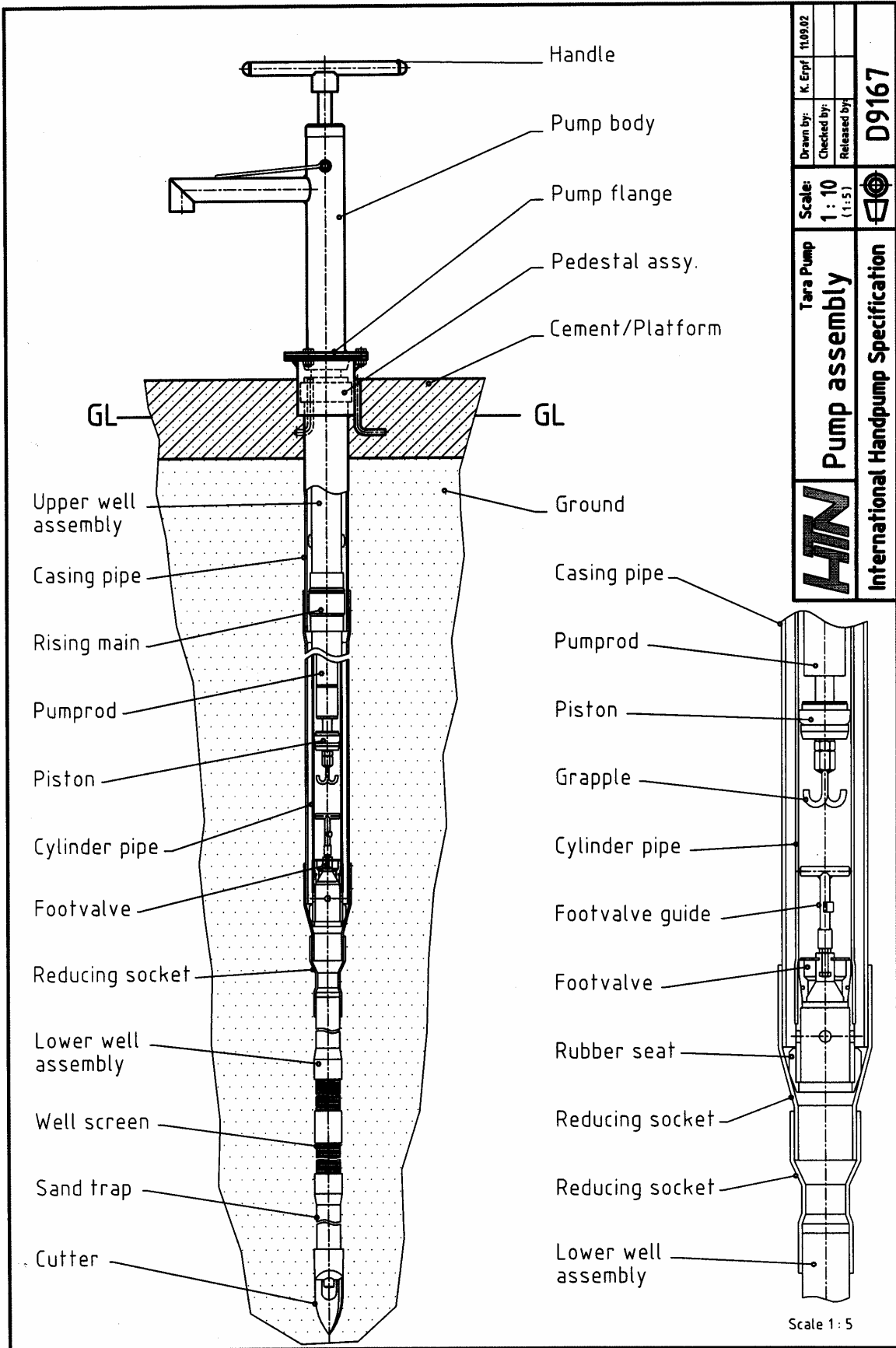

Drawn by:	K. Erpf	110902
Checked by:		
Released by:		
Scale:	1:10	(1:5)
Tara Pump Pump assembly		
International Handpump Specification		
		D9167

Scale 1:5

Tara Pump, India

Options

A

B

Pump stand type	Pump stand with Handle & Pedestal:	---
------------------------	------------------------------------	-----

Rising main arrangement	PVC-U Rising main with lower well casing	PVC-U Rising main with upper and lower well casing
--------------------------------	--	--

Cylinder arrangement	PVC-U Cylinder PVC-U / SS Plunger and Footvalve	---
-----------------------------	--	-----

Pumprod arrangement	PVC-U Pumprod pipes with union connectors	---
----------------------------	---	-----

Abbreviations:

PVC-U Polyvinyl Chloride (unplastcized)
SS Stainless Steel

Example:

Possible composition of a selected Tara Pump:

Pump stand type	A
Rising main arrangement	B
Cylinder arrangement	A
Pumprod arrangement	A

For more clarification see the 2 following pages!

Pump stand & Pedestal

(approx. scale = 1 : 10)

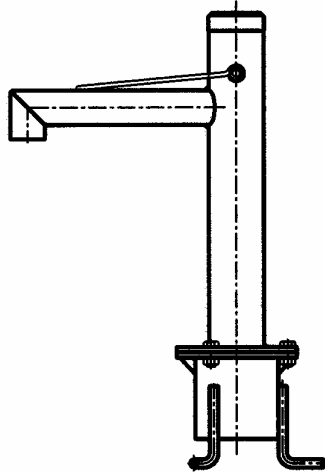

Handle & Pumprod pipe

(approx. scale = 1 : 10)

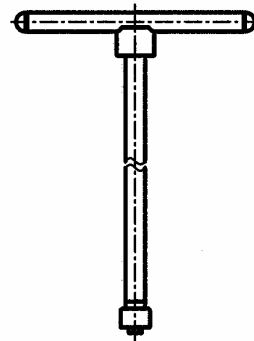

Pumprod pipe

(approx. scale = 1 : 5)

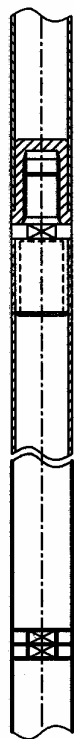

Pumprod pipes
are available
in 3 m lengths

Piston & Footvalve

(approx. scale = 1 : 5)

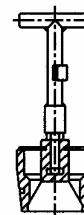

Rising main, Cylinder, Upper & Lower casing

(approx. scale = 1 : 10)

Rising main, Cylinder & Lower well assembly

(approx. scale = 1 : 10)

Options:

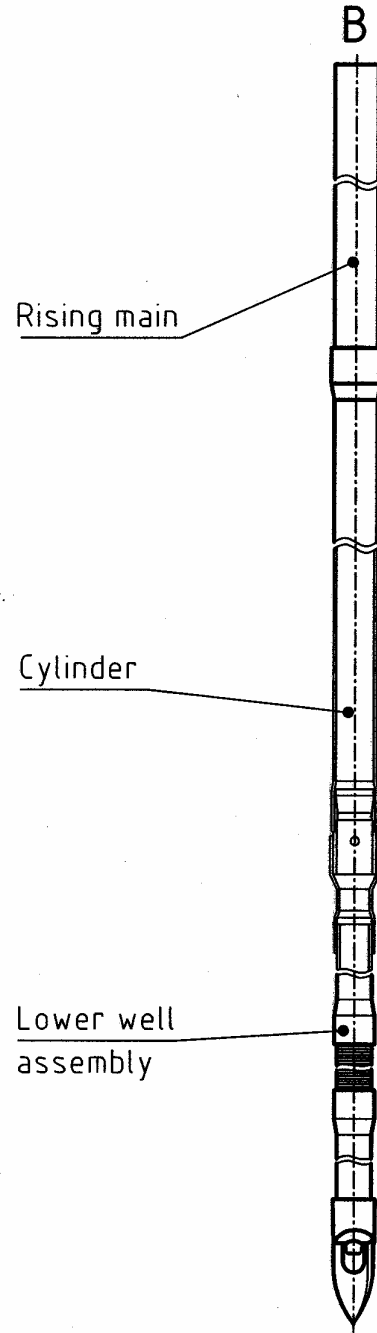
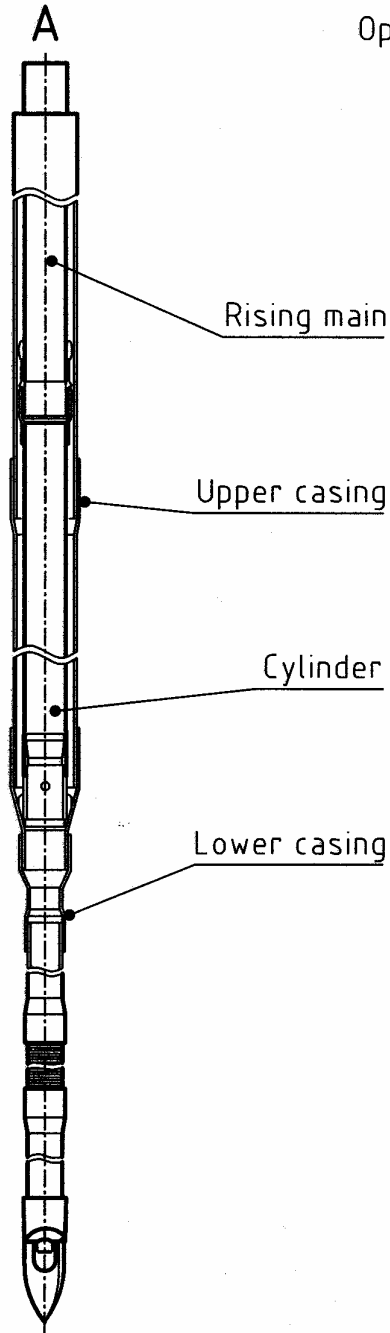

3.) Rotary Pumps for Shallow, Medium and Deep Wells

Rope Pump, Madagascar

SKAT-HTN Document (Edition 2001)

recommended use between depths of 0 to 30 m.

Supporting documents:

Handpump Specification
Manufacturing Guidelines

Revision 0-2001

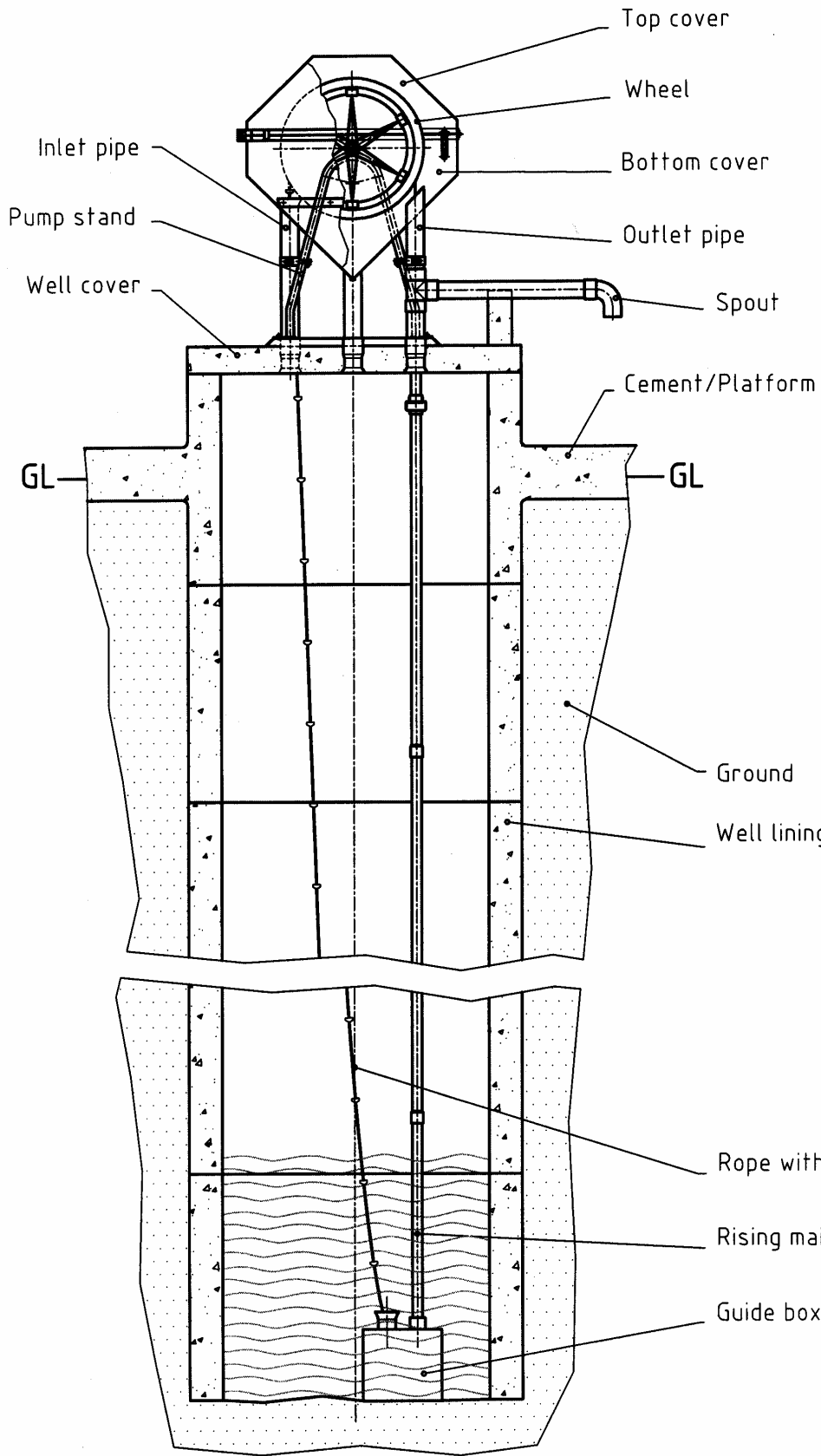

	Madagascar Rope Pump		Drawn by: K. Eprf	30.11.01
	Pump assembly		Checked by:	
	International Handpump Specification		Released by:	
Scale: 1:20				D9100

Rope Pump Madagascar

Pump stand	Pump stand with Wheel, Handle & Cover
-------------------	---------------------------------------

Pipe arrangement	PVC-U pipes for Rising main, Spout, Inlet & Drainage
-------------------------	--

Guide box	Concrete block with Glass bottle (deviation), PVC-U adaptors
------------------	--

Rope & Pistons	PA or PP Rope (woven) with PVC-U Pistons
---------------------------	--

Abbreviations:

PVC-U Polyvinyl Chloride (unplastcized)
PA Polyamide
PP Polypropylene

Note: This Rope Pump type can only be used for dug wells.

For more clarification see the following page!

Pump stand with Wheel, Handle & Cover

(approx. scale = 1 : 11)

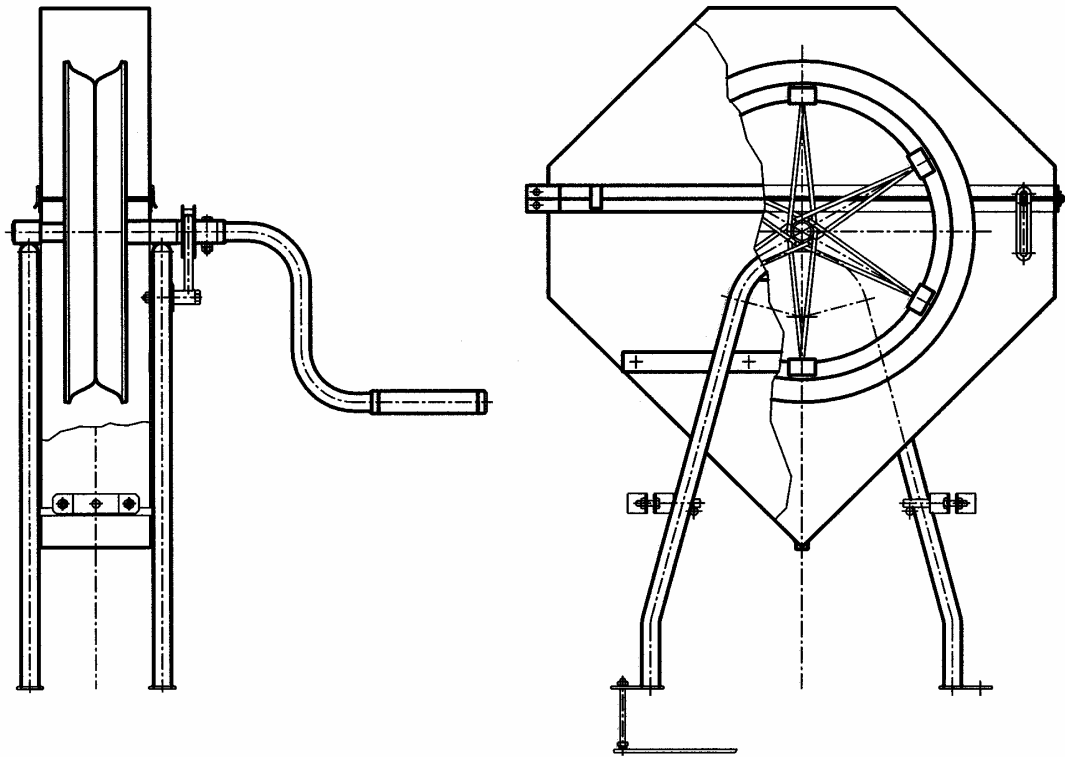

Inlet-, Drainage-, Spout pipe

(approx. scale = 1 : 11)

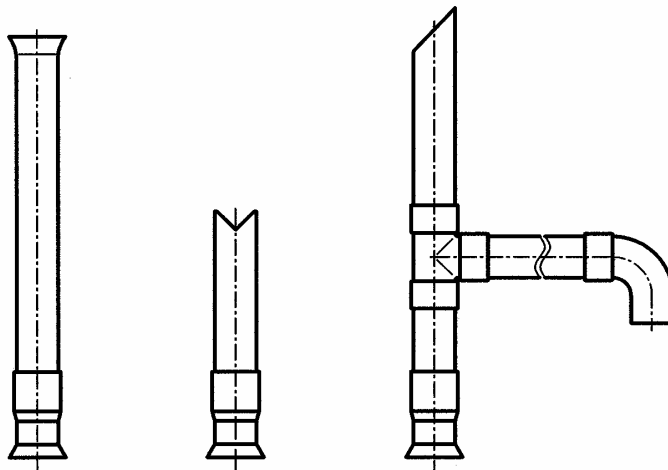

Guide box, Rising main

(approx. scale = 1 : 11)

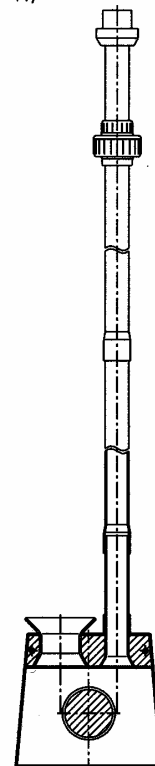

All pipes are of PVC-U

Rope Pump, Nicaragua

Bombas de Mecate Documents

Information available from Bombas de Mecate (see address in Appendix II)

4.) Lever Operated Pumps for Medium and Deep Wells

Jibon Pump, Bangladesh

SKAT-HTN Document (Edition 1999)

recommended use between depths of 0 to 20 m.

Supporting documents:

Handpump Specification

Revision 0-2001

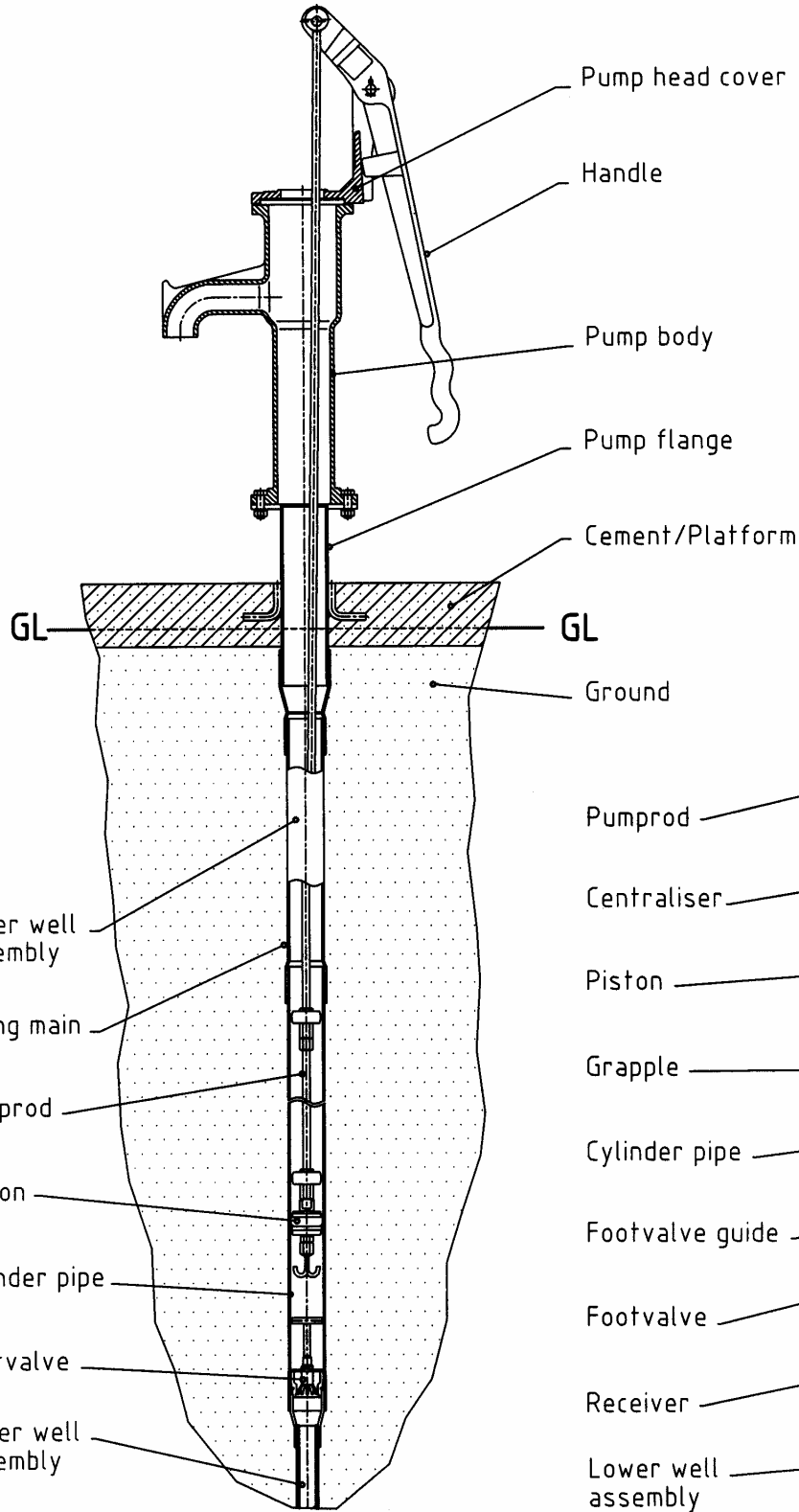

HTN	Drawn by: K. Erpf	13.12.00
	Checked by:	
	Released by:	
Jibon Deepset Pump 2"		
Pump assembly		
Scale: 1:10 (1:5)		D9097
International Handpump Specification		

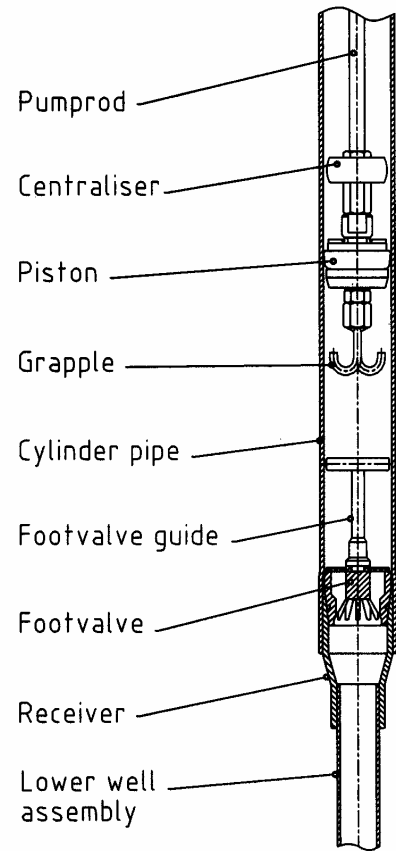

Scale 1:5

Jibon Pump, Bangladesh

List of options available for this pump type.

Options	A	B	C
Pump head type	Cast-iron Pump head cover and Handle	---	---
Pump stand type	Cast-iron Pump body with welded Flange assembly	---	---
Rising main arrangement	PVC-U Rising main for 2 " cylinder & Lower well assy.	(1 ½" version in preparation)	(3" version in preparation)
Cylinder arrangement	Upper well assy. with: Piston & Footvalve drawing No. A5820	(1 ½" version in preparation)	(3" version in preparation)
Pumprod arrangement	* MS- Pumprods with threaded connectors: drawing No. A5804	FRP- Pumprods with Brass connectors: drawing No. A5889	---

Explanations:

* not recommended when PH value is < 6.5

Abbreviations:

PVC-U Polyvinyl Chloride (unplastcized)
 MS Mild Steel
 FRP Fibre Reinforced Plastic

For more clarification see the following page!

Pump stand, Handle & Pedestal

(approx. scale = 1 : 10)

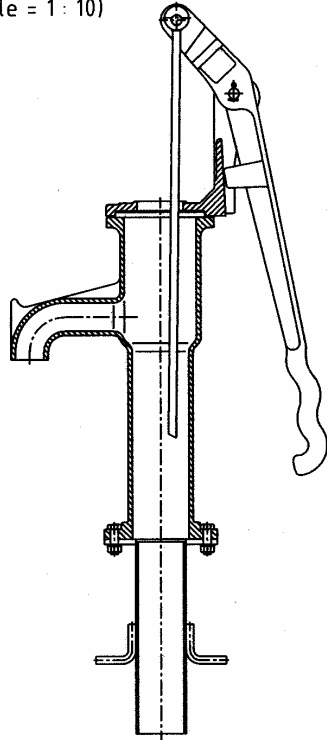

Piston & Footvalve

(approx. scale = 1 : 5)



Pumprod arrangements

(approx. scale = 1 : 5)

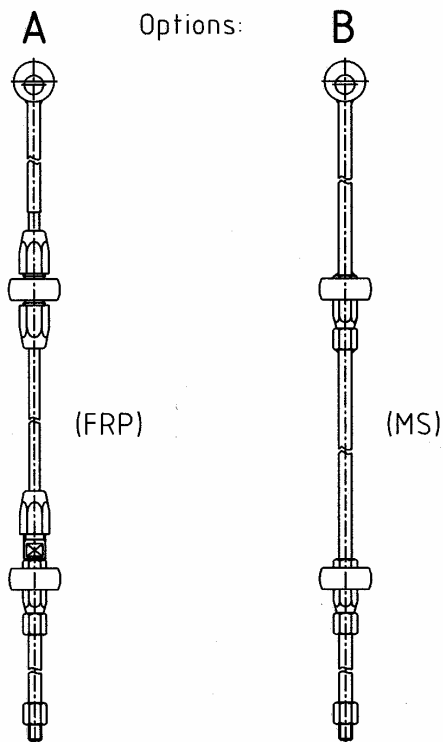

Both Pumprod types are available in 3 m lengths

Cylinder, Rising main & Lower well assembly

(approx. scale = 1 : 5)

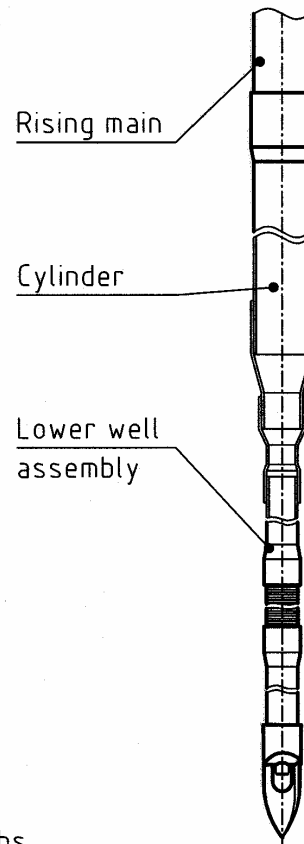

Walimi Handpump, Tanzania

SKAT-HTN Document (Edition 2002)

Ø3" cylinder to be used between depths of 5 to 25 m,
Ø2" cylinder to be used between depths of 20 to 40 m.

Supporting documents:

Handpump Specification

Installation and Maintenance Manual

Quality Control Guidelines

Other documents: - Manufacturing Guidelines

Revision 0-2002

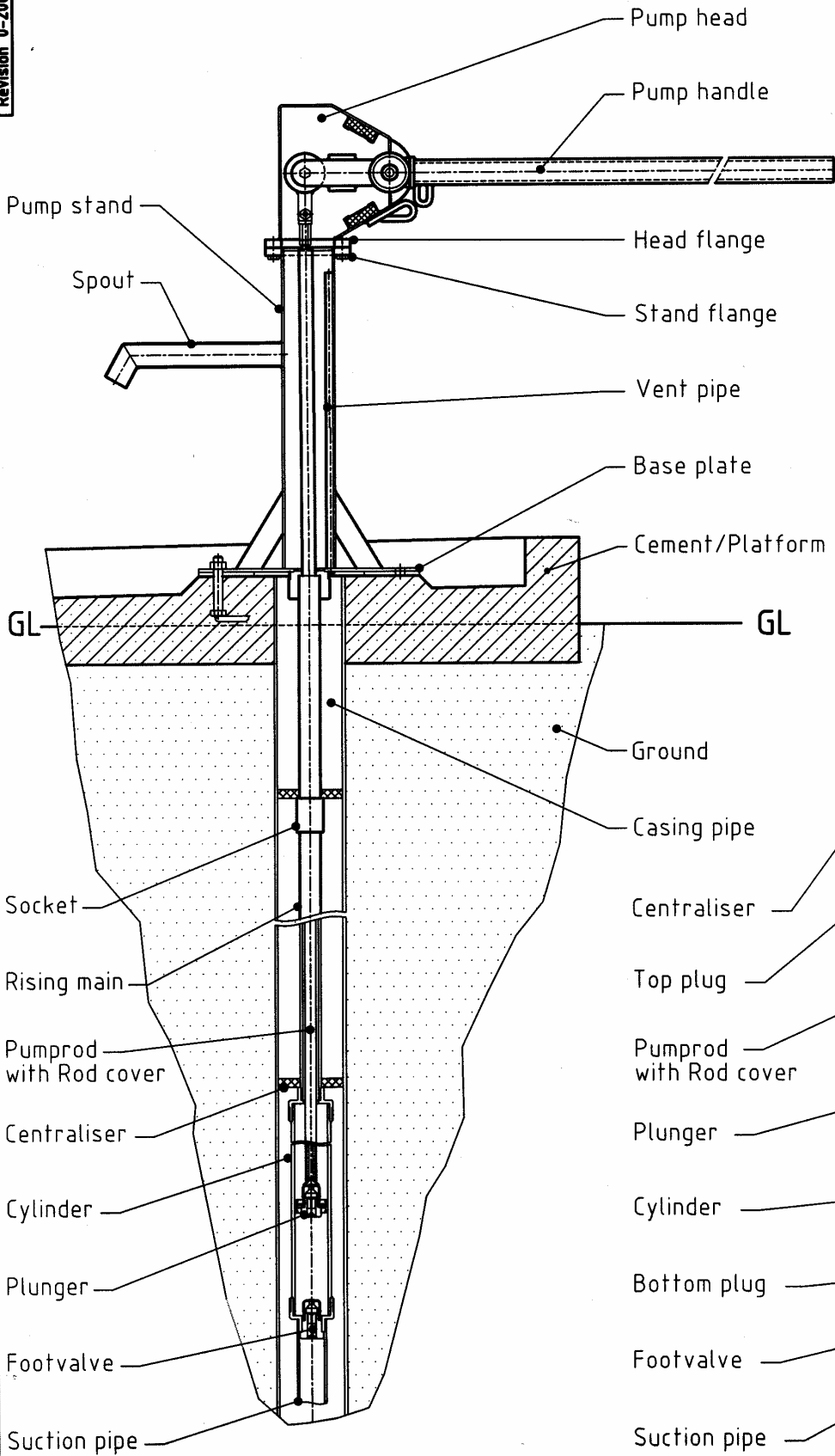

Drawn by:	K. Erpf	16.07.01
Checked by:	[Signature]	08.05.02
Released by:	[Signature]	08.05.02

D9053

Scale: 1:10 (1:5)

HTN Pump assembly
Walmi Pump (SWN 80)

International Handpump Specification

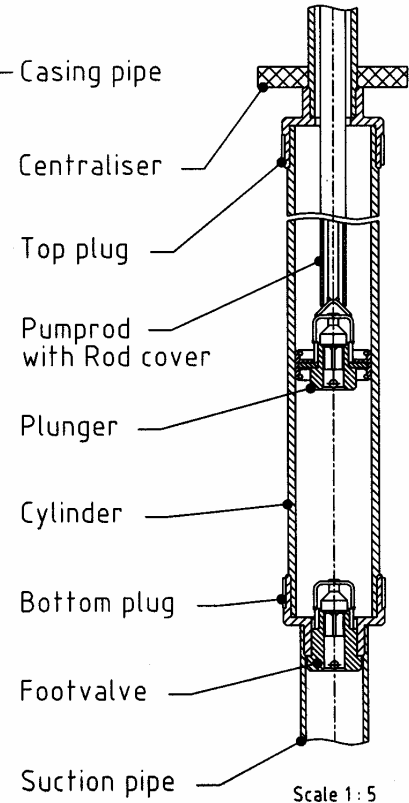

Scale 1:5

Walimi Handpump, Tanzania

List of options available for this pump type.

Options	A	B	C	D
Pump head type	Pump head assy. with Handle drawing No. A3002	---	---	---
Pump stand type	Long stand with long spout and bottom flange: drawing No. A3030	Long stand with short spout and bottom flange: drawing No. A3030	Short stand with long spout and bottom flange: drawing No. A3110	Short stand with short spout and bottom flange: drawing No. A3110
Rising main arrangement	PVC-HI Rising main with "Sockets": drawing No. A3079	---	---	---
Cylinder arrangement	PVC-HI Cylinder (3") & Plunger/Footvalve drawing No. A3050	PVC-HI Cylinder (2") & Plunger/Footvalve drawing No. A3095	---	---
Pumprod arrangement	SS- Pumprods with threaded connectors: drawing No. A3040	---	---	---

Abbreviations:

PVC-HI Polyvinyl Chloride (High Impact)
 SS Stainless Steel

Example:

Possible composition of a selected Walimi Handpump:

Pump head type	A
Pump stand type	D
Rising main arrangement	A
Cylinder arrangement	B
Pumprod arrangement	A

For more clarification see the following 2 pages!

Pump head & Handle

(approx. scale = 1 : 10)



Pump stand types

(approx. scale = 1 : 10)

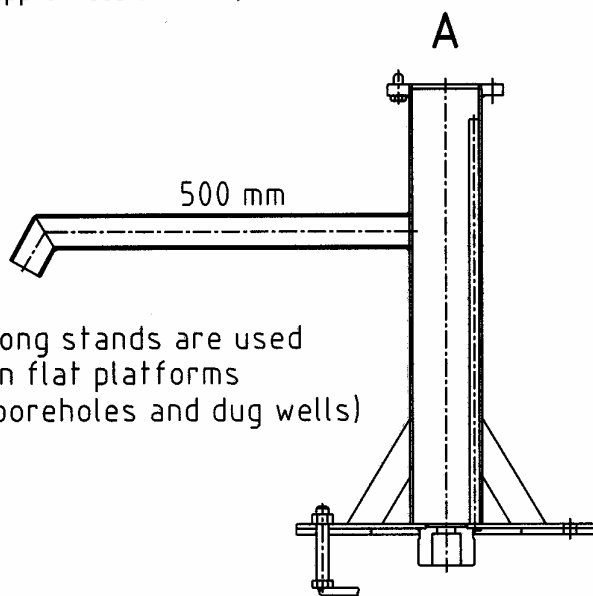

Long stands are used on flat platforms (boreholes and dug wells)

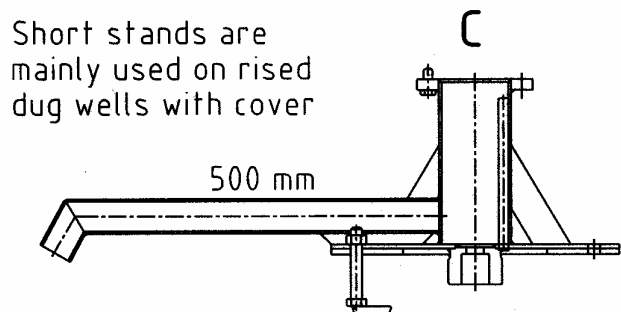
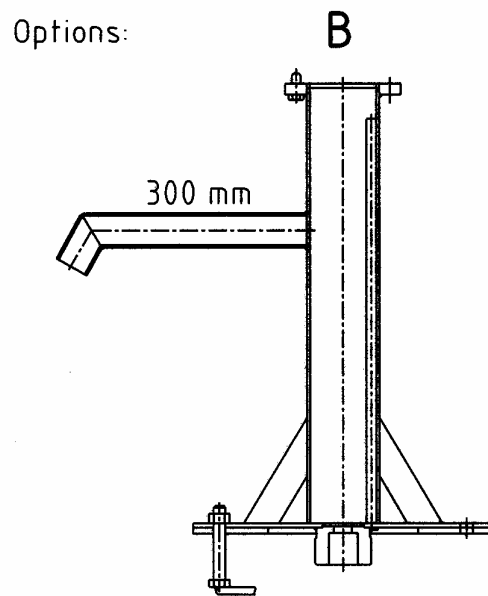

Short stands are mainly used on rised dug wells with cover

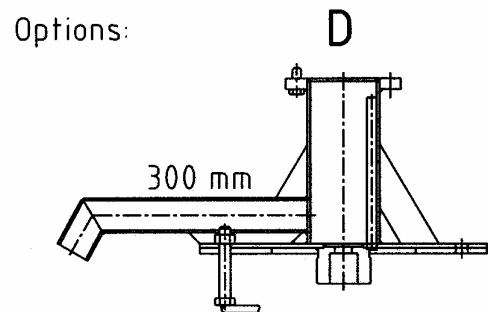

Pumprod arrangement

(approx. scale = 1 : 10)

SS Pumprods and
LDPE Rod covers
are available in
0.75 m lengths
1.5 m lengths
2.0 m lengths



Rising main arrangement

(approx. scale = 1 : 10)

PVC-HI Riser pipes
are available in
0.75 m lengths
1.5 m lengths
2.0 m lengths

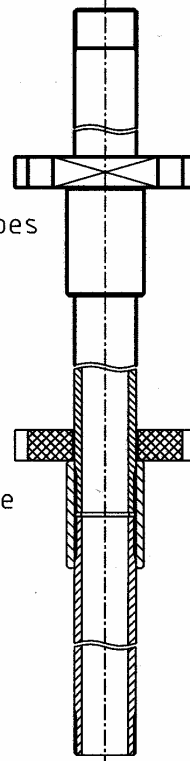

IMPORTANT
Select applicable
Centraliser size
for Casing used
4"
5"
6"

Cylinder arrangements

(approx. scale = 1 : 10)

A

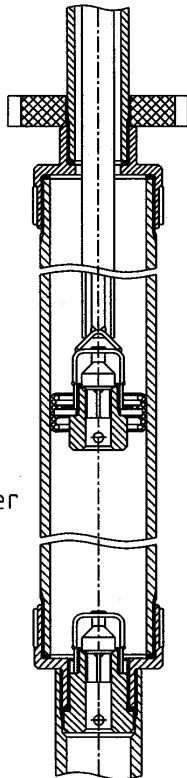

3" Cylinder
(PVC-HI)

Options:

B

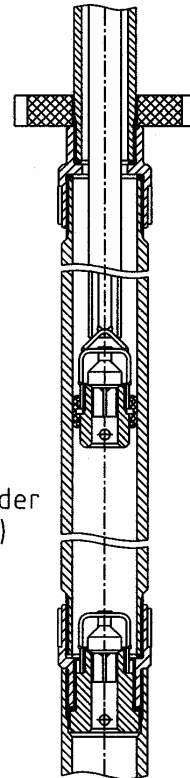

2" Cylinder
(PVC-HI)

India Mark II Pump

India Standard Document, IS 9301 : 1990

recommended use between depths of 20 to 50 m.

Supporting documents:

Handpump Specification, available from BIS (see address in Appendix II),

Installation and Maintenance Manual, available from the manufacturers.

Revision 0-2001

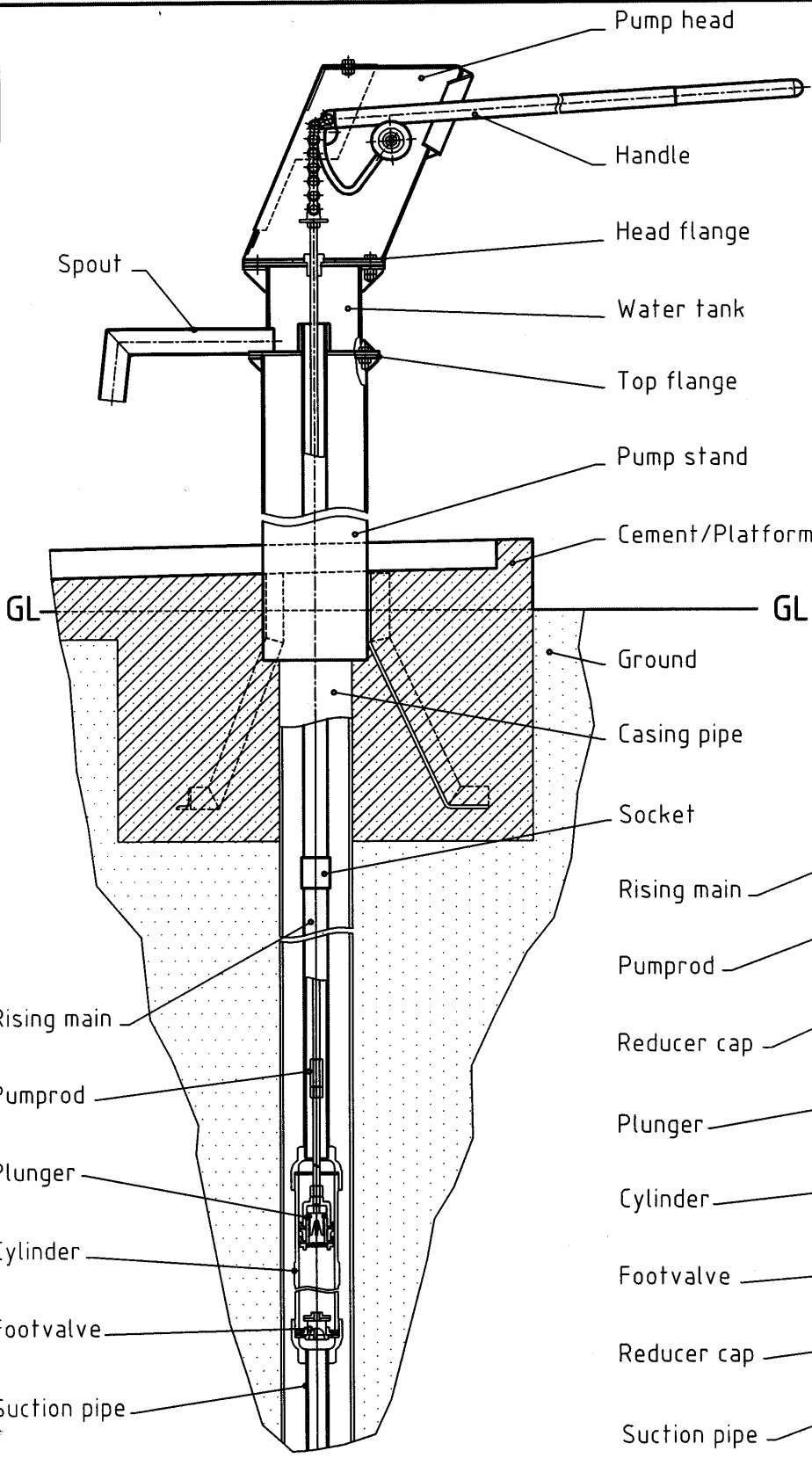

Scale:	1 : 10 (1:5)
India Mark II	
Drawn by:	K. Erpf
Checked by:	
Released by:	

D9096

Scale: 1 : 10 (1:5)

HTN Pump assembly

International Handpump Specification

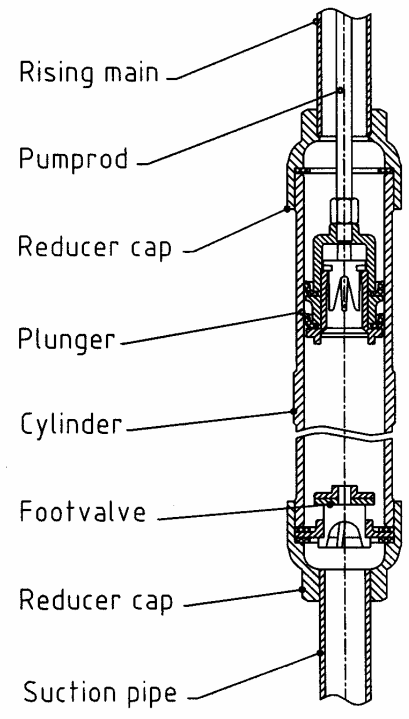

Scale 1 : 5

India Mark II Pump

List of options available for this pump type.

Options	A	B
Pump head type	Pump head with standard Handle and Water tank	---
Pump stand type	Pump stand with 3 legs (NB 150 mm) drawing No. B2348	Pump stand with 3 legs (NB 150/175) drawing No. B2347
Rising main arrangement	Galvanized GI pipe with Sockets (1 1/4" medium)	---
Cylinder arrangement	Castiron cylinder, Brass plunger & footvalve: drawing No. A2350	---
Pumprod arrangement	MS- Pumprods with threaded connectors: drawing No. A2370	---

Explanations:

* should not be used in aggressive waters

Abbreviations:

NB Nominal Bore
 GI Galvanized Iron
 MS Mild Steel

Example:

Possible composition of a selected India Mark II Pump:

Pump head type	A
Pump stand type	B
Rising main arrangement	A
Cylinder arrangement	A
Pumprod arrangement	A

For more clarification see the following 2 pages!

Pump head, Handle and Water tank

(approx. scale = 1 : 10)

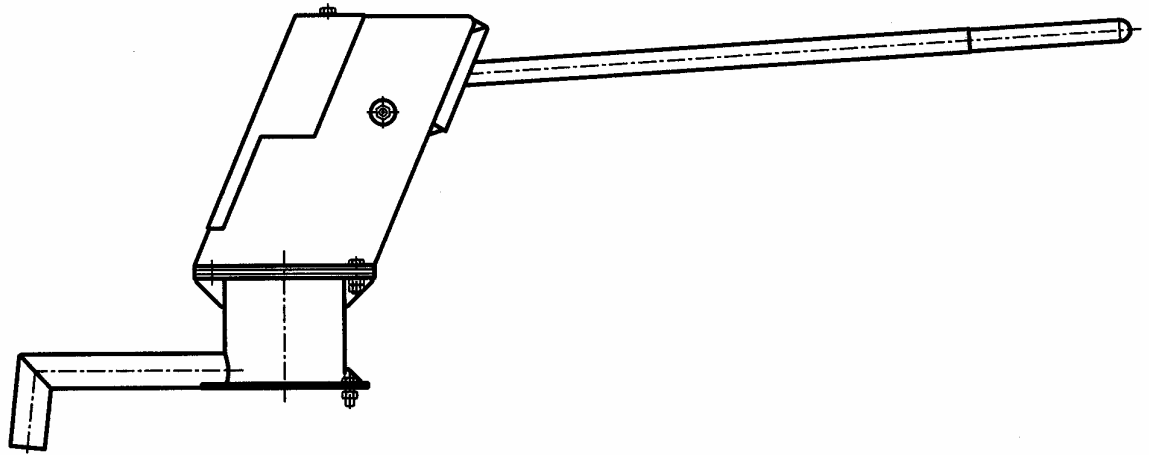

Pump stand types

(approx. scale = 1 : 10)

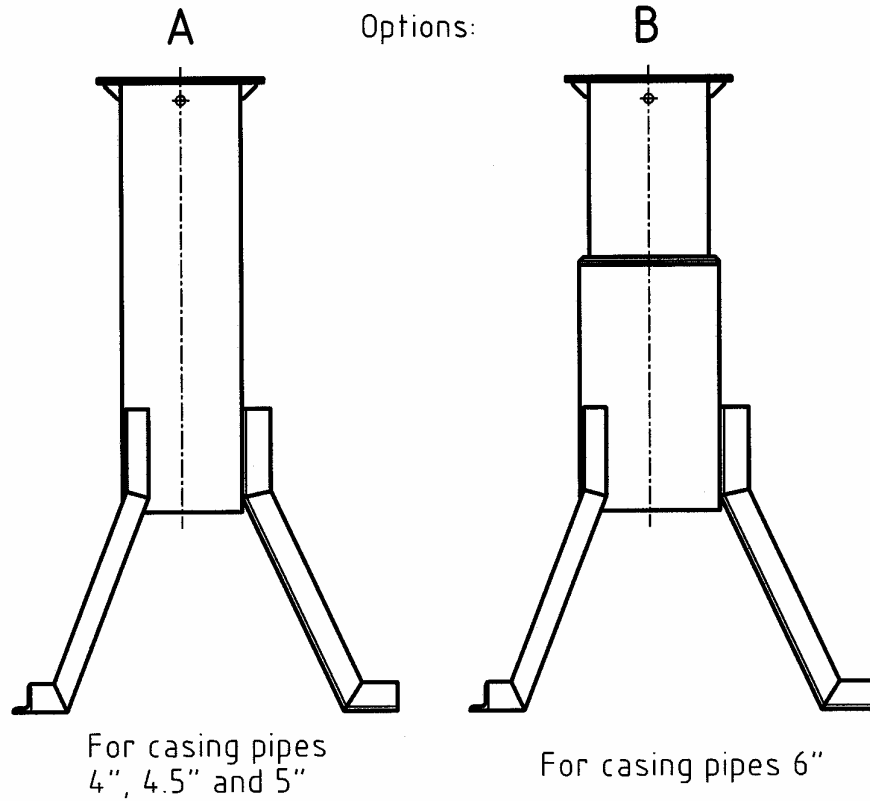

Rising main arrangement

(approx. scale = 1 : 5)



GI Riser pipes
are available
in 3 m lengths

Cylinder arrangement

(approx. scale = 1 : 5)

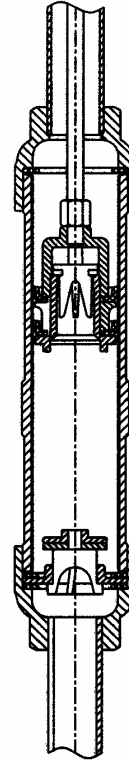

Pumprod arrangement

(approx. scale = 1 : 5)



Pumprods are
available in
3 m lengths

India Mark III Pump

India Standard Document, IS 13056 : 1991

recommended use between depths of 10 to 30 m.

Supporting documents:

Handpump Specification, available from BIS (see address in Appendix II)

Installation and Maintenance Manual (English and French version), available from the manufacturers.

Revision 0-2001

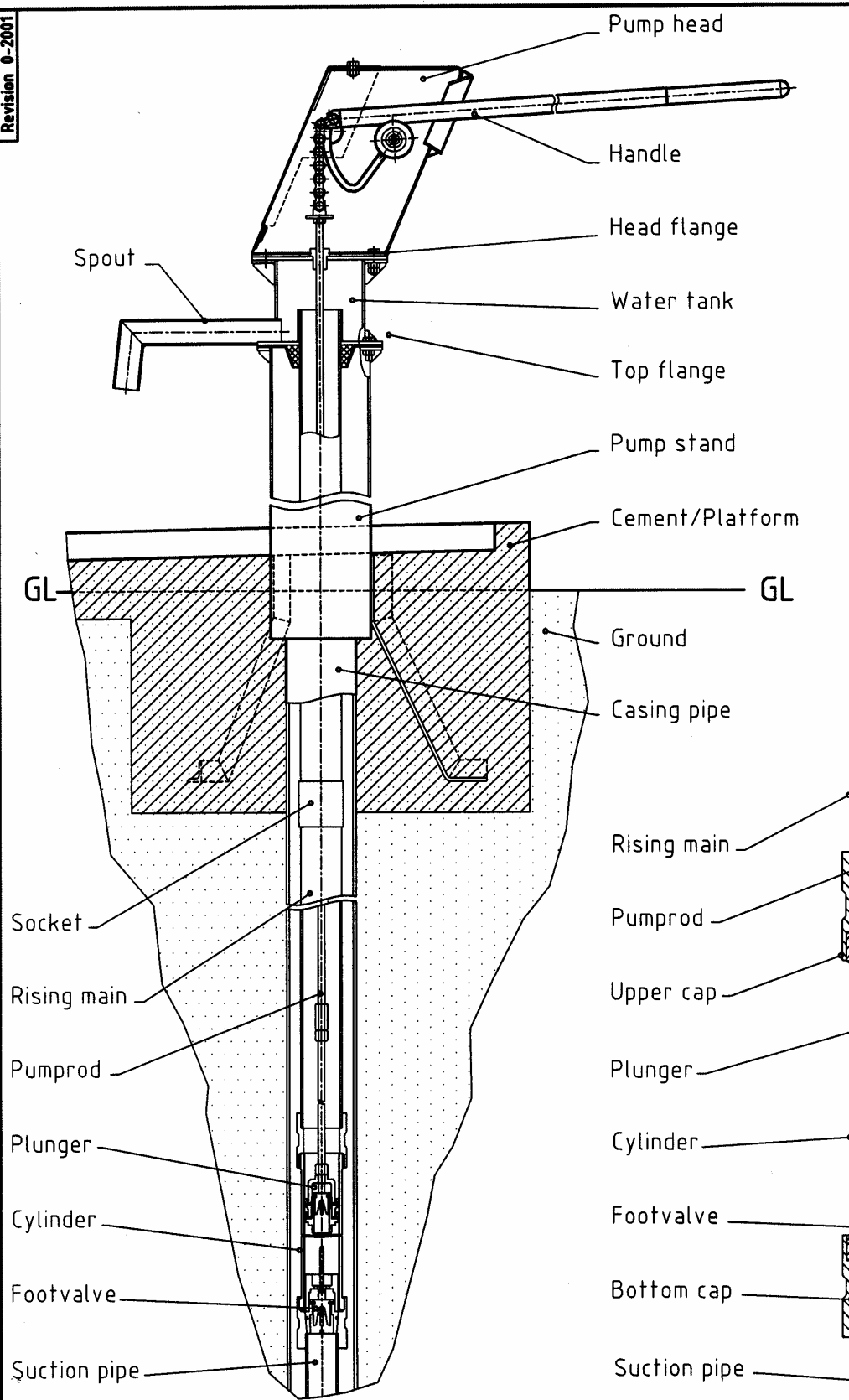

	India Mark III Pump assembly	Scale: 1 : 10 (1:5)	D9099
	International Handpump Specification	Drawn by: K. Erpf Checked by: Released by:	13.12.00

Scale 1 : 5

India Mark III Pump

List of options available for this pump type.

Options

A

B

Pump head type	Pump head with Handle and Water tank for 2" Risers pipes	Pump head with Handle and Water tank for 2 ½" Risers pipes
-----------------------	--	--

Pump stand type	Pump stand with 3 legs (NB 150 mm) drawing No. B2348	Pump stand with 3 legs (NB 150/175) drawing No. B2347
------------------------	--	---

Rising main arrangement	Galvanized GI pipe with Sockets for 2" Risers pipes	Galvanized GI pipe with Sockets for 2 ½" Risers pipes
--------------------------------	---	---

Cylinder arrangement	Castiron cylinder with Brass liner for Ø50 mm, Plunger & Footvalve: drawing No. A2651	Castiron cylinder with Brass liner for Ø63.5 mm, Plunger & Footvalve: drawing No. A2751
-----------------------------	---	---

*

Pumprod arrangement	MS- Pumprods with threaded connectors: drawing No. A2206	---
----------------------------	--	-----

Explanations:

* should not be used in aggressive waters

Abbreviations:

NB Nominal Bore
 GI Galvanized Iron
 MS Mild Steel

Example:

Possible composition of a selected India Mark III Pump:

Pump head type	B
Pump stand type	A
Rising main arrangement	B
Cylinder arrangement	B
Pumprod arrangement	A

For more clarification see the following 2 pages!

Pump head, Handle and Water tank

(approx. scale = 1 : 10)

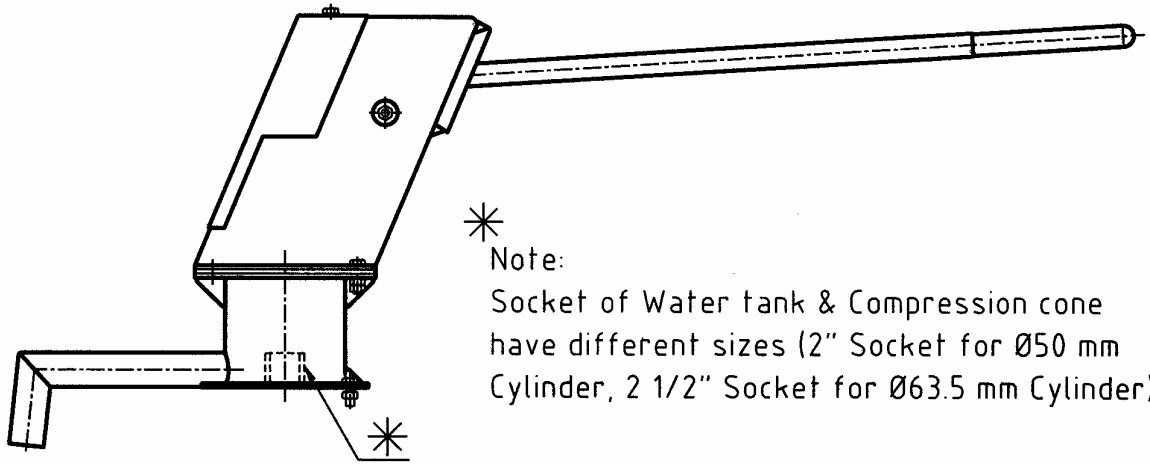

*
Note:
Socket of Water tank & Compression cone
have different sizes (2" Socket for Ø50 mm
Cylinder, 2 1/2" Socket for Ø63.5 mm Cylinder)

Pump stand types

(approx. scale = 1 : 10)

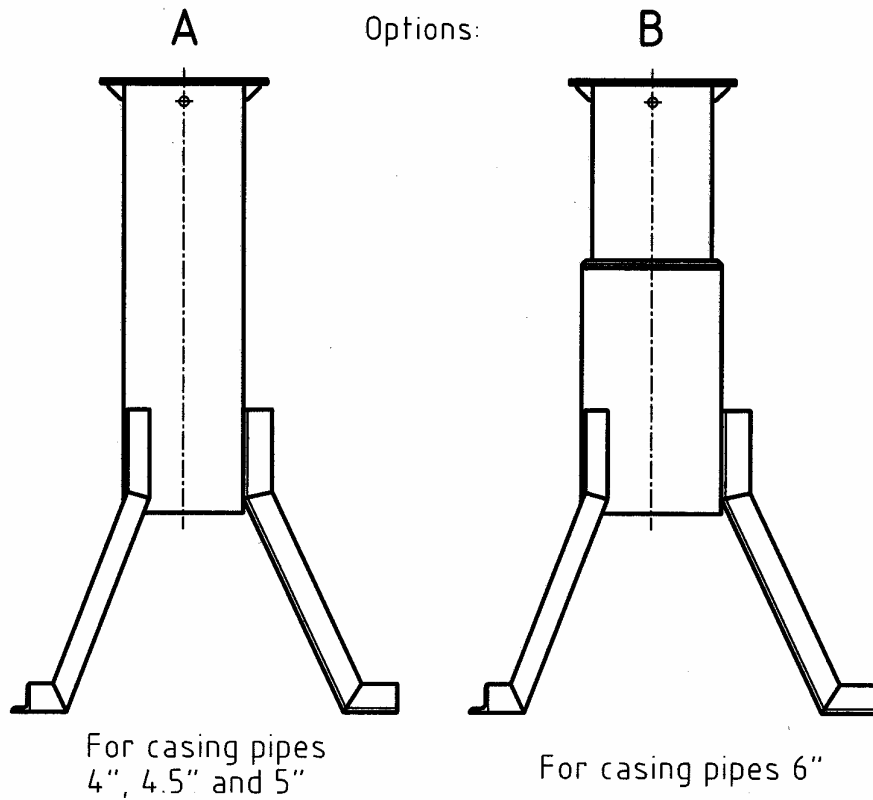

Cylinder arrangements

(approx. scale = 1 : 5)

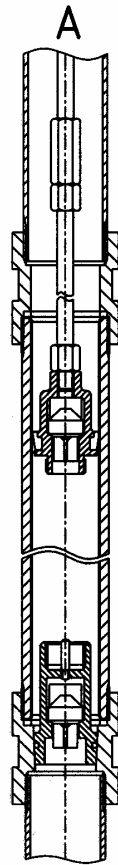

Options:

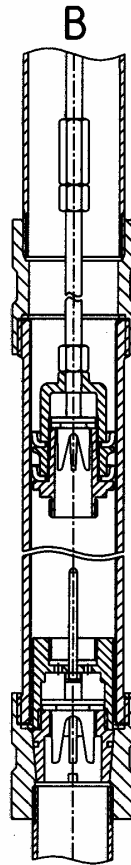

Rising main arrangements

(approx. scale = 1 : 5)

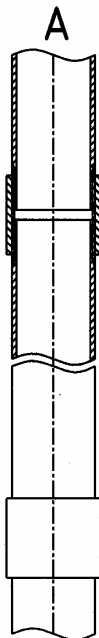

Options:

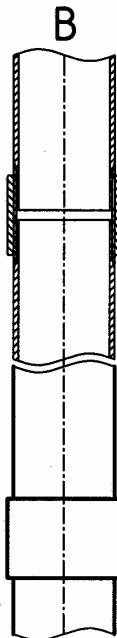

GI Riser pipes are available in 3 m lengths

2"

2 1/2"

Pumprod arrangement

(approx. scale = 1 : 5)



Pumprods are available in 3 m lengths

U3M Handpump, Uganda

SKAT-HTN Document (Edition 2001)

recommended use between depths of 10 to 45 m.

Supporting documents:

- Handpump Specification
- Installation and Maintenance Manual
- Quality Control Guidelines

Revision 0-2001

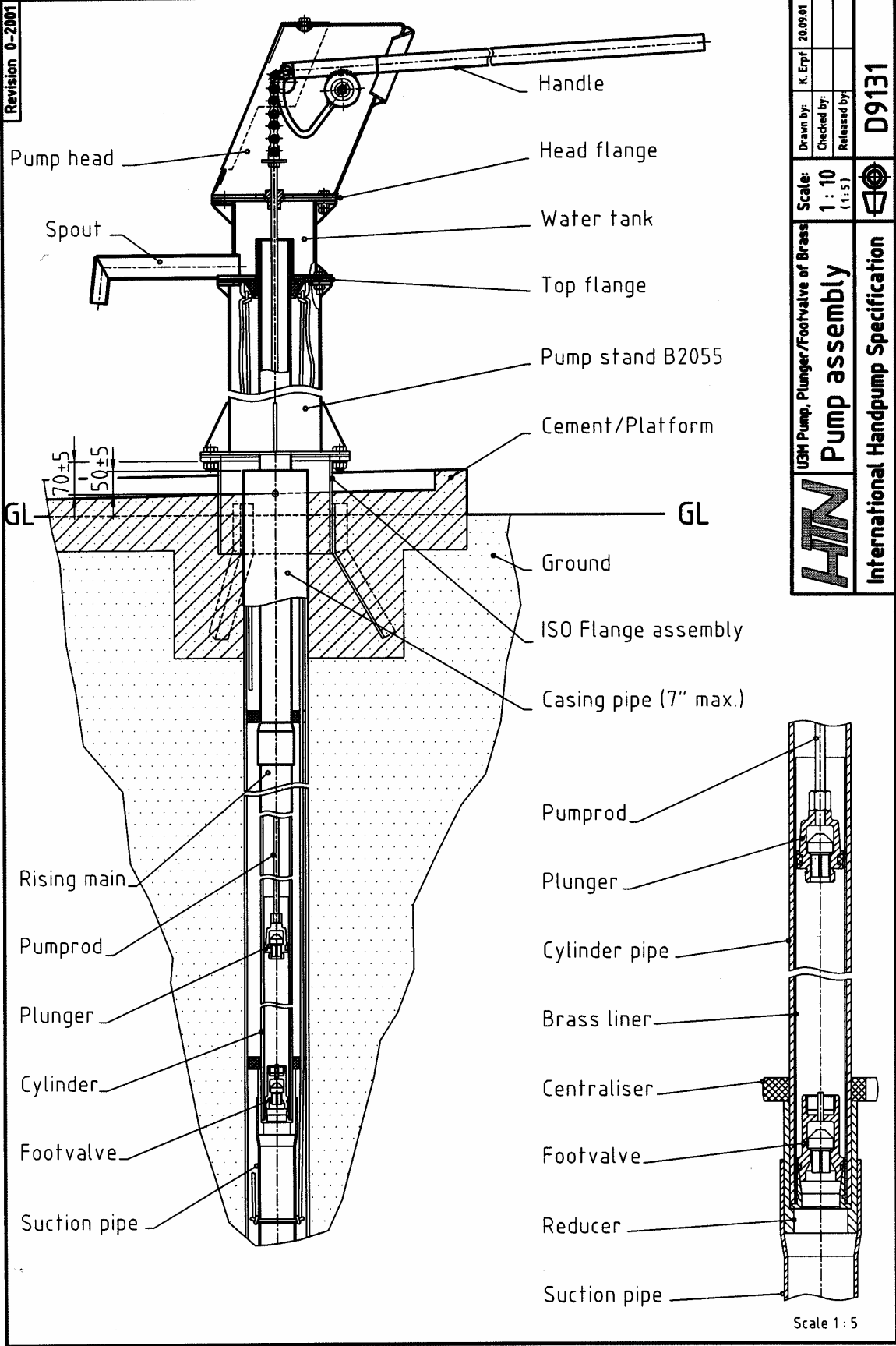

	U3M Pump, Plunger/Footvalve of Brass	Scale: 1 : 10 (1:5)	Drawn by: K. Erpf 20.09.01
	Pump assembly		Checked by:
	International Handpump Specification		Released by:

D9131

U3M Handpump, Uganda

List of options available for this pump type.

Options	A	B	C	D
Pump head type	Pump head with lightweight handle drawing No. B2276	Pump head with heavy handle drawing No. B2279	---	---
Pump stand type	Pump stand with bottom flange: drawing No. B2287	Pump stand with 3 legs (NB 150 mm) drawing No. B2281	Pump stand with 3 legs (NB 150/175) drawing No. B2284	Pump stand with bottom flange: drawing No. B2055
Rising main arrangement	PVC-U Rising main with "Sockets": drawing No. A2119	PVC-U Rising main with "Bell ends": drawing No. A2099	---	---
Cylinder arrangement	Brass plunger with Brass footvalve: drawing No. A2296	Brass plunger with Plastic footvalve: drawing No. A2257	---	---
Pumprod arrangement	SS- Pumprods with threaded connectors: drawing No. A2224	FRP- Pumprods with Brass connectors: drawing No. A5889	---	---

Abbreviations:

PVC-U Polyvinyl Chloride (unplasticized)
 SS Stainless Steel
 FRP Fibre Reinforced Plastic

Example:

Possible composition of a selected U3M Handpump:

Pump head type	A
Pump stand type	C
Rising main arrangement	B
Cylinder arrangement	B
Pumprod arrangement	A

For more clarification see the following 3 pages!

Pump head types

(approx. scale = 1 : 10)

Option: A

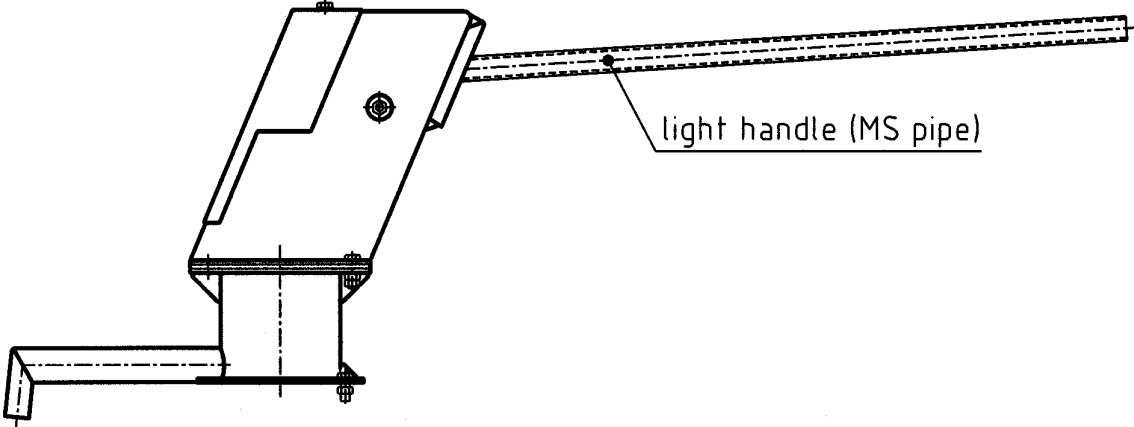

Option: B

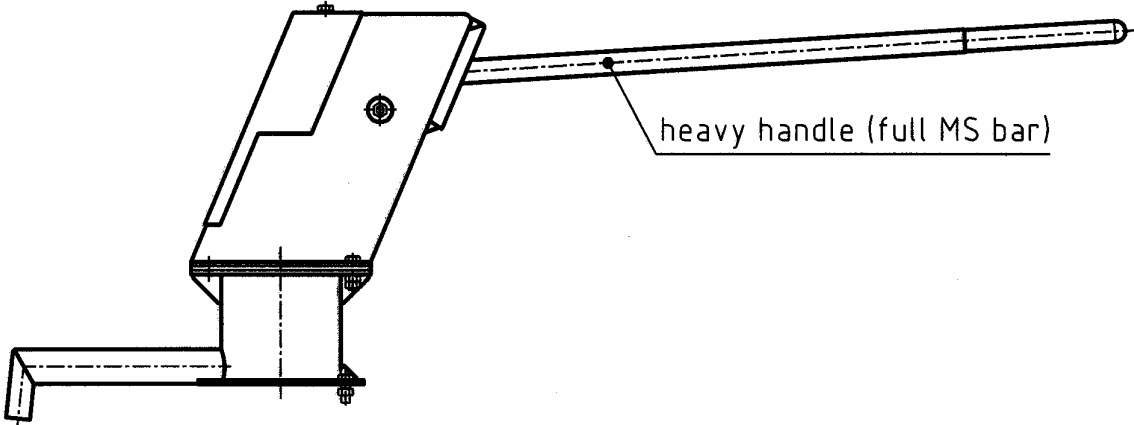

Pump stand types

(approx. scale = 1 : 10)

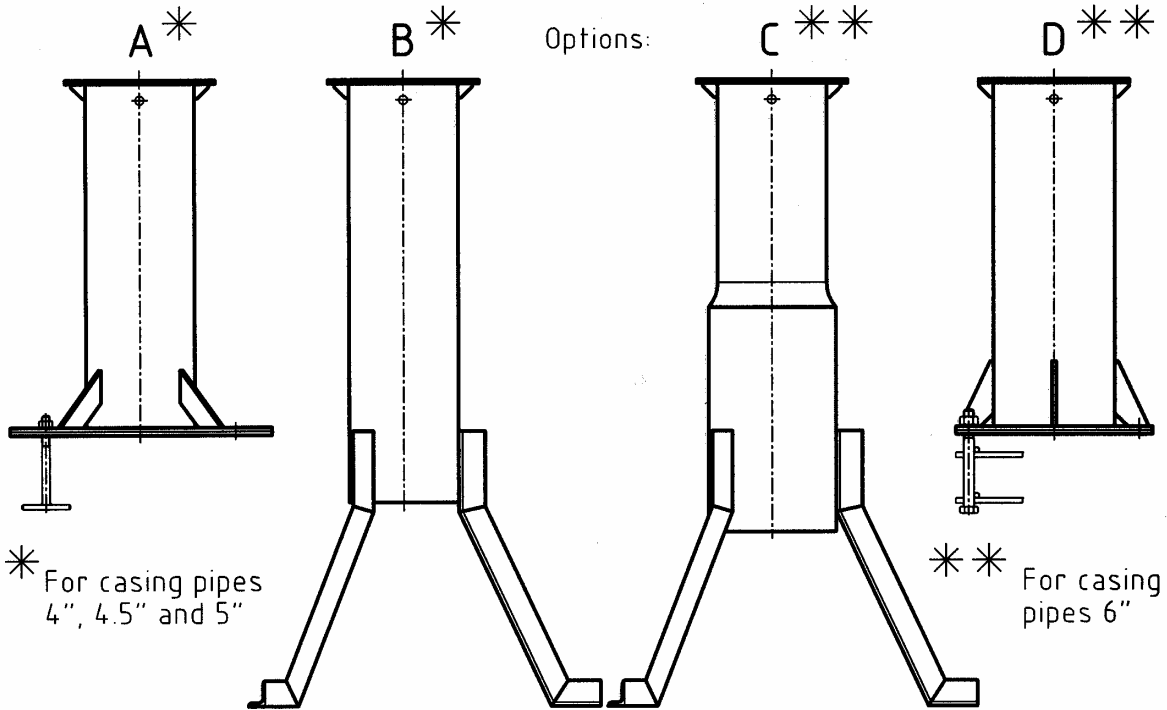

* For casing pipes
4", 4.5" and 5"

** For casing pipes 6"

Rising main arrangements

(approx. scale = 1 : 10)

IMPORTANT

State applicable
Centraliser size
for Casing used

- 4"
- 4.5"
- 5"
- 6"
- 8"

PVC-U Riser pipes
(pipes / sockets)
are available in
3 m lengths

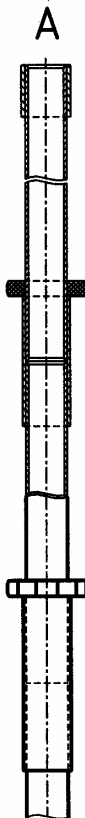

Options:

IMPORTANT

State applicable
Centraliser size
for Casing used

- 4"
- 4.5"
- 5"
- 6"
- 8"

PVC-U Riser pipes
(with bell-ends)
are available in
2.9 m lengths

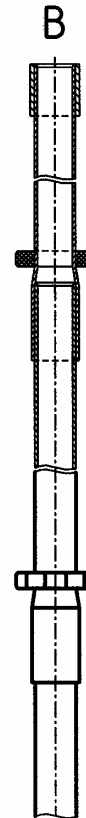

Cylinder arrangements

(approx. scale = 1 : 5)

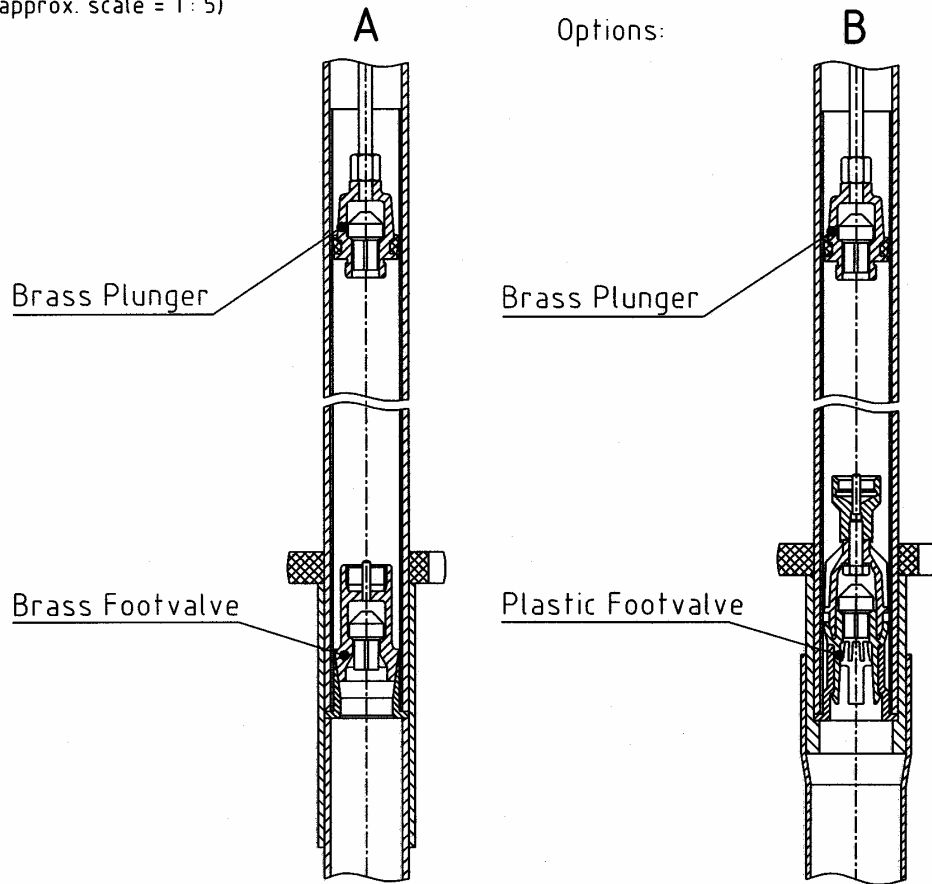

Pumprod arrangements

(approx. scale = 1 : 5)

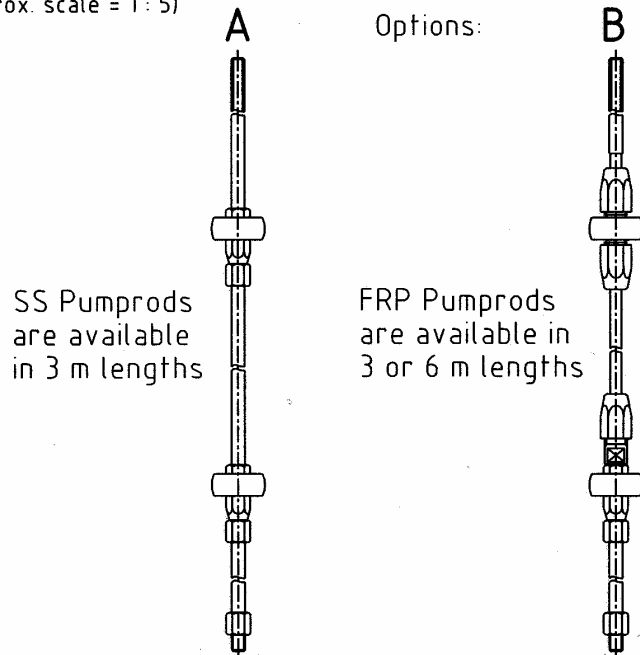

Afridev Handpump

SKAT-HTN Document (Revision 4-2002)

recommended use between depths of 10 to 45 m.

Supporting documents:

Handpump Specification

Installation and Maintenance Manual (English and French version)

Quality Control Guidelines

Other supporting documents: - Injection Moulding Guidelines

- Rubber Moulding Guidelines

Revision 0-2002

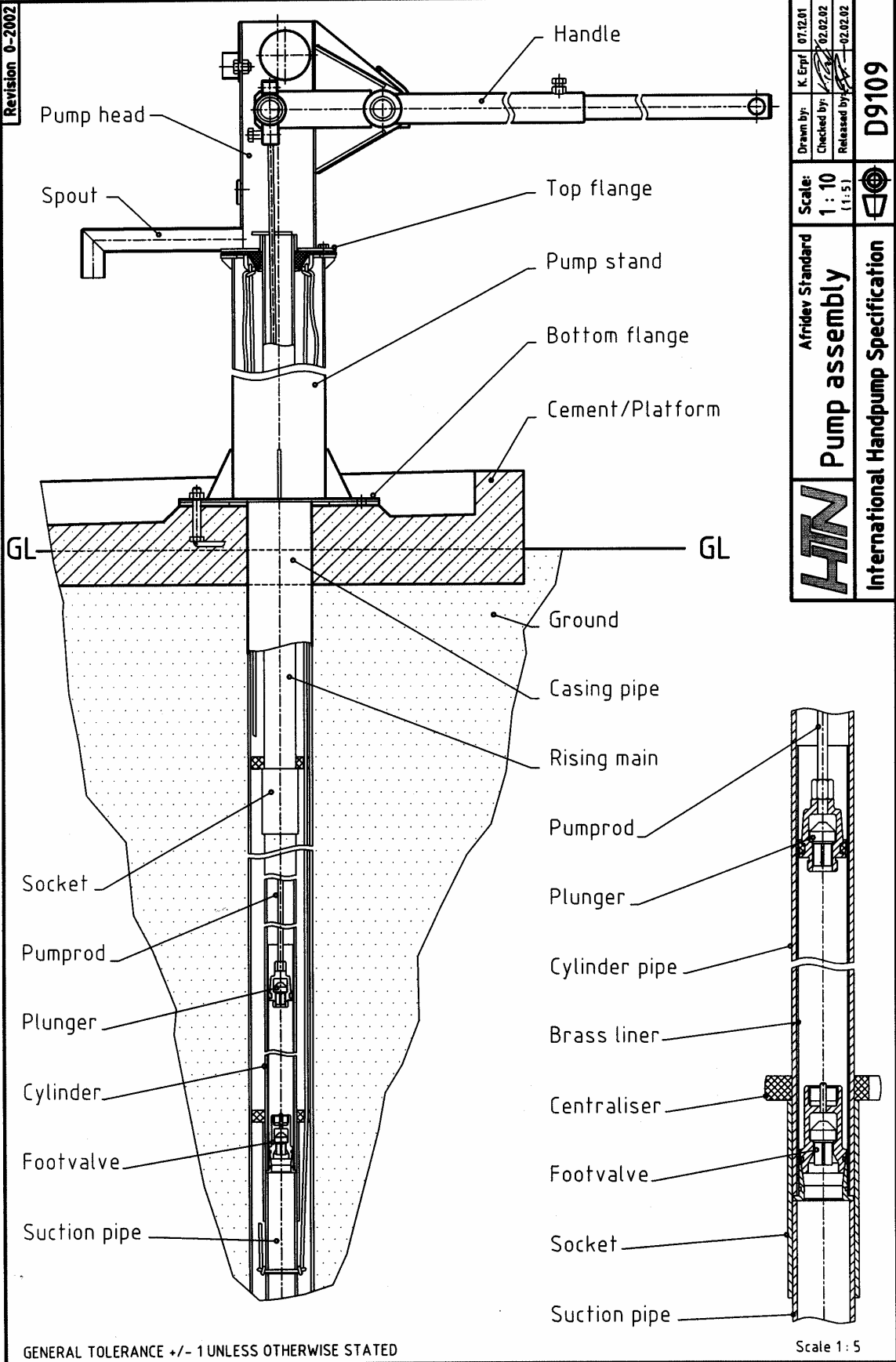

Drawn by: K. Erpf	07.02.01		Pump assembly International Handpump Specification
Checked by:	02.02.02		
Released by:	02.02.02		
Scale: 1 : 10 (1:5)			D9109

GENERAL TOLERANCE +/- 1 UNLESS OTHERWISE STATED

Scale 1 : 5

Afridev Handpump

List of options available for this pump type.

Options	A	B	C	D
Pump head type	Pump head with short spout: (30 cm) drawing No. B2003	Pump head with long spout: (58 cm) drawing No. B2003	---	---
Pump stand type	Pump stand with bottom flange: drawing No. B2055	Pump stand with 3 legs: drawing No. B2050	Pump stand with ISO flange arrangement: drawing No. B2048	---
Rising main arrangement	PVC-U Rising main with "Sockets": drawing No. A2119	PVC-U Rising main with "Bell ends": drawing No. A2099	---	---
Cylinder arrangement	Brass plunger with Brass footvalve: drawing No. A2296	Brass plunger with Plastic footvalve: drawing No. A2257	Plastic plunger with Plastic footvalve: drawing No. A2070	---
Pumprod arrangement	MS- Pumprods with threaded connectors: drawing No. A2206	SS- Pumprods with threaded connectors: drawing No. A2209	FRP- Pumprods with Brass connectors: drawing No. A5889	SS- Pumprods with "Hook & Eye" conn. drawing No. A2110

Explanations:

- * not any longer recommended
- ** not recommended when PH value is < 6.5

Abbreviations:

ISO	International Standard Organisation
PVC-U	Polyvinyl Chloride (unplastcized)
MS	Mild Steel
SS	Stainless Steel
FRP	Fibre Reinforced Plastic

Example:

Possible composition of a selected Afridev Handpump:

Pump head type	B
Pump stand type	C
Rising main arrangement	A
Cylinder arrangement	A
Pumprod arrangement	C

For more clarification see the following 3 pages!

Pump head types

(approx. scale = 1 : 10)

Option: **A**

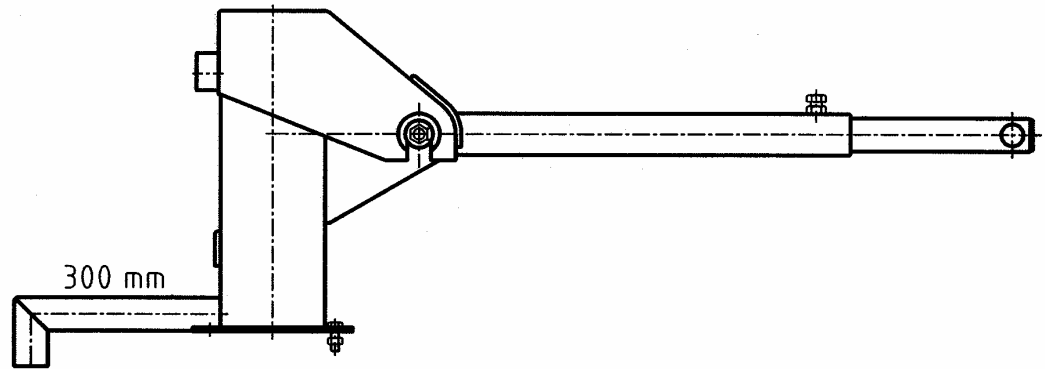

Option: **B**

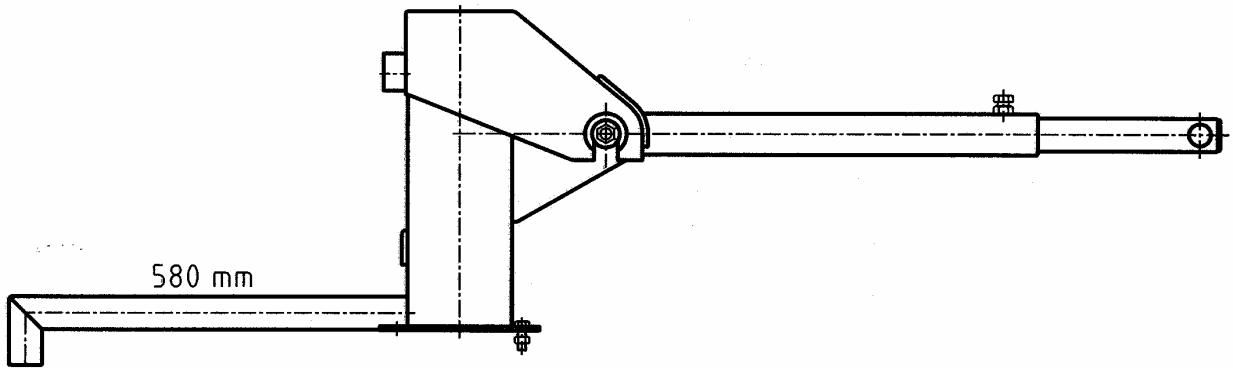

Pump stand types

(approx. scale = 1: 10)

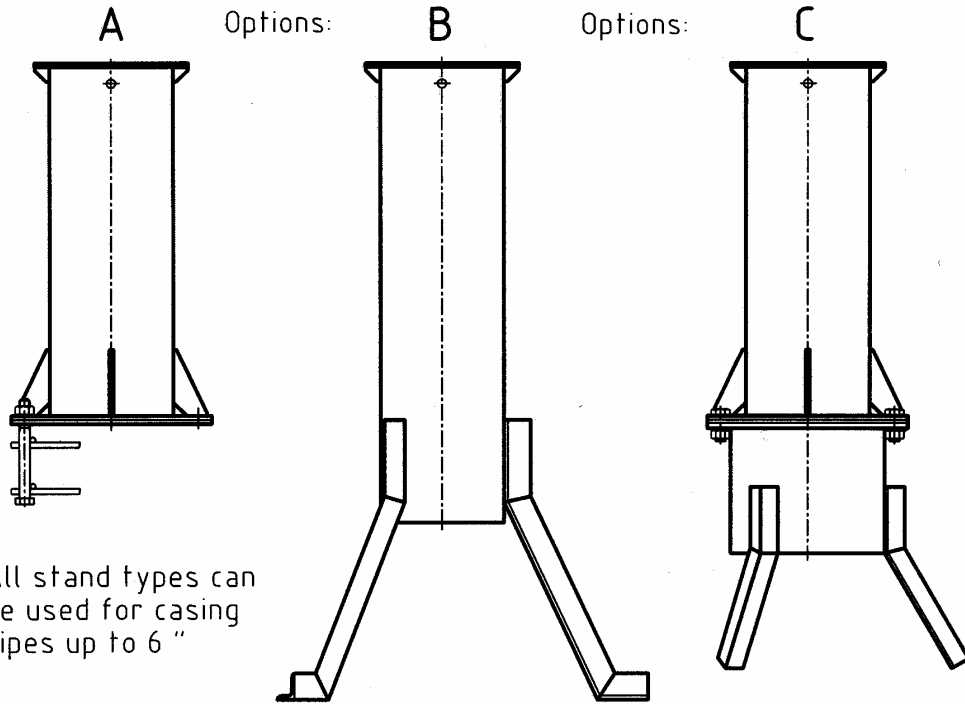

All stand types can be used for casing pipes up to 6"

Rising main arrangements

(approx. scale = 1: 10)

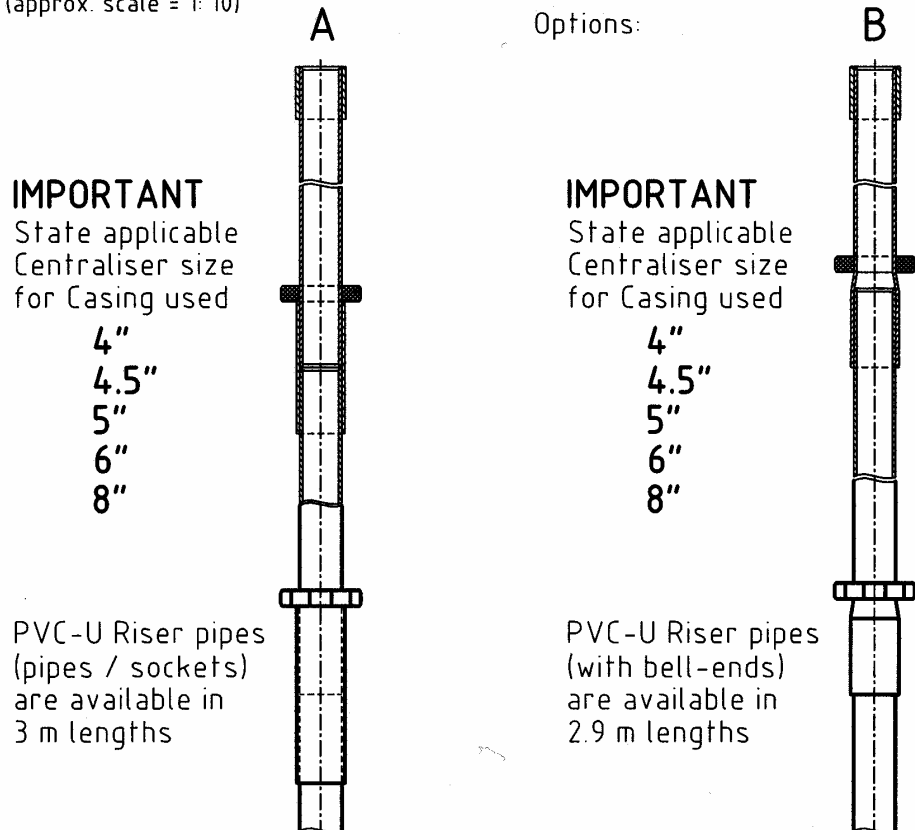

IMPORTANT
State applicable
Centraliser size
for Casing used

4"
4.5"
5"
6"
8"

PVC-U Riser pipes
(pipes / sockets)
are available in
3 m lengths

IMPORTANT
State applicable
Centraliser size
for Casing used

4"
4.5"
5"
6"
8"

PVC-U Riser pipes
(with bell-ends)
are available in
2.9 m lengths

Cylinder arrangements

(approx. scale = 1 : 5)

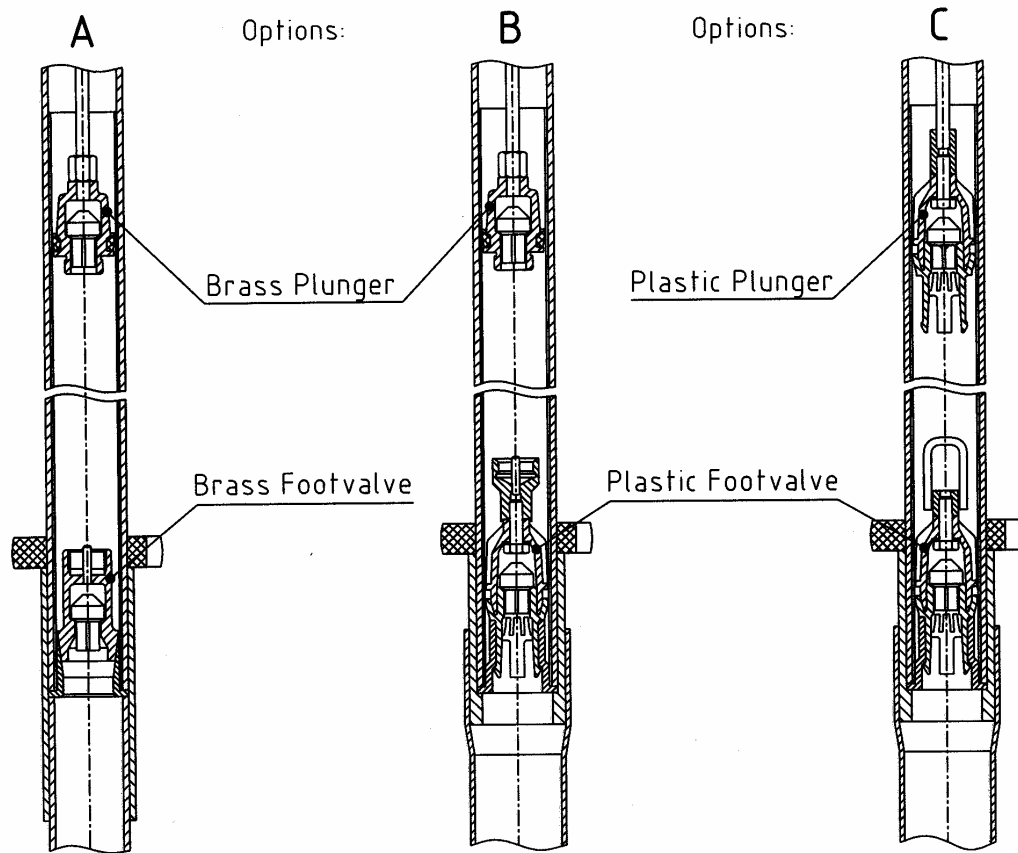

Pumprod arrangements

(approx. scale = 1 : 5)

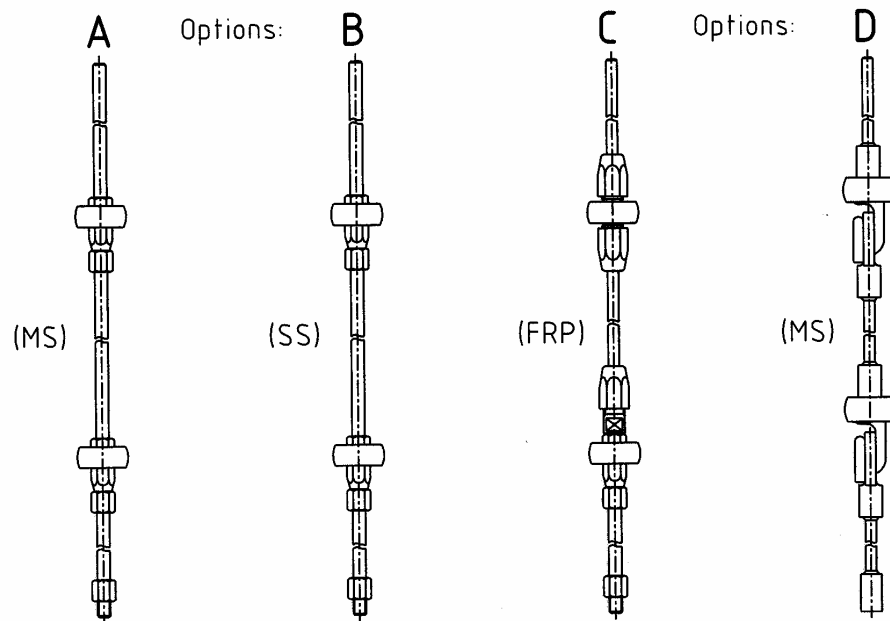

Options A,B and C are available in 3 m lengths - Option C in 3 or 6 m lengths

Bush Pump, Zimbabwe

SKAT-HTN Document (Edition 1999)

Ø75 mm cylinder to be used between depths of 3 to 25 m,
Ø63.5 mm cylinder to be used between depths of 20 to 45 m.
Ø50 mm cylinder to be used between depths of 40 to 80 m.

Supporting documents:

Handpump Specification

Installation and Maintenance Manual

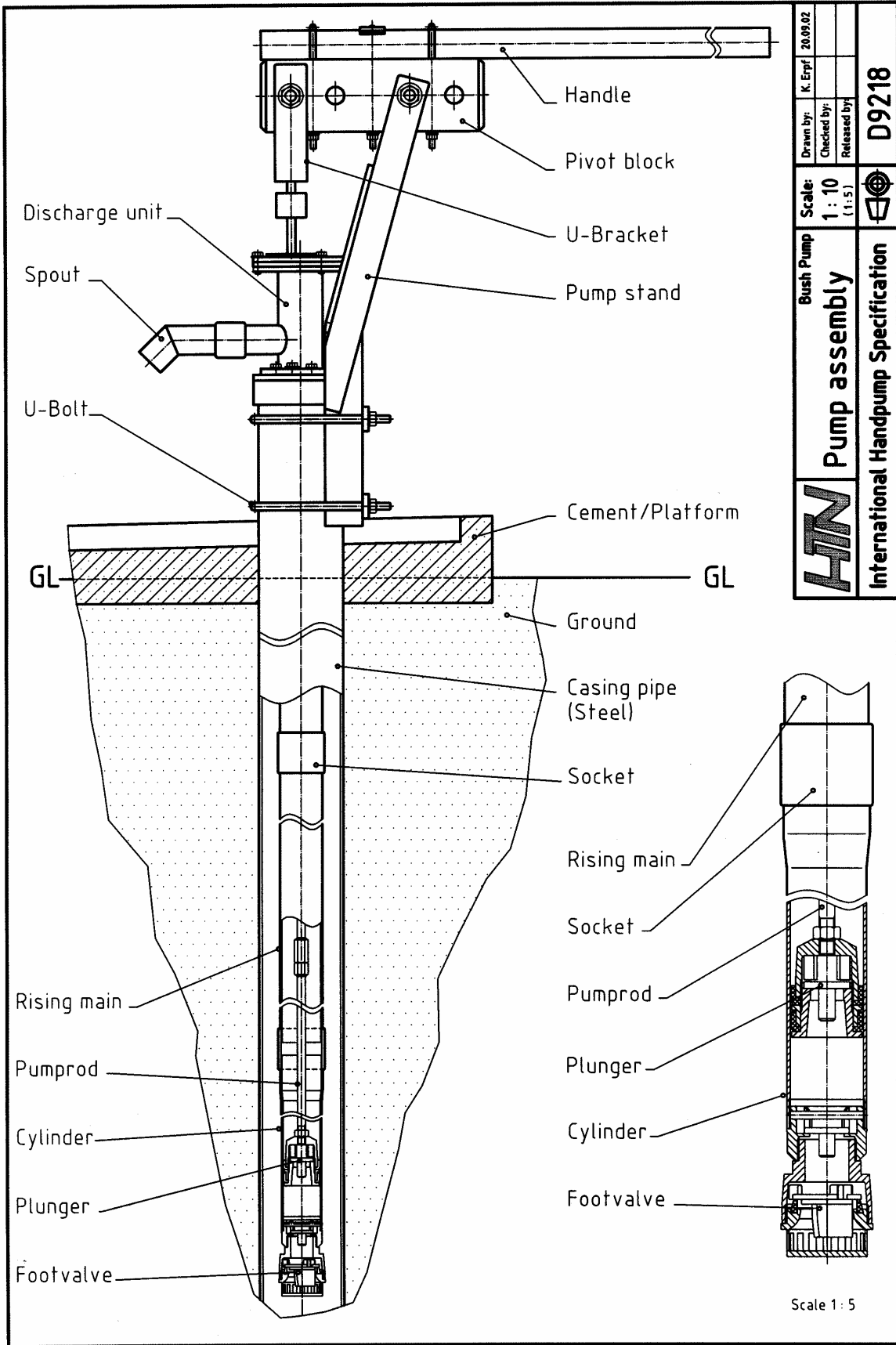

	Scale:	1 : 10 (1:5)		D9218	
	Drawn by:	K. Erpf			20.09.02
	Checked by:				
Bush Pump		Pump assembly		International Handpump Specification	

Scale 1 : 5

Bush Pump, Zimbabwe

List of options available for this pump type.

Options	A Ø50 mm ES	B Ø63.5 mm ES	C Ø75 mm ES	D Ø75 mm NES
Pump stand type	Pump stand, Handle & Discharge assembly: drawing No. A3202	same as "A"	same as "A"	same as "A"
Discharge type	Discharge assembly for 2" Riser pipes: drawing No. A3301	Discharge assembly for 2 1/2" Riser pipes: drawing No. A3218	Discharge assembly for 3" Riser pipes: drawing No. A3331	Discharge assembly for 2" Riser pipes: drawing No. A3301
Rising main pipe	GI Riser pipe (2") and "Sockets": drawing No. C3309/04	GI Riser pipe (2 1/2") and "Sockets": drawing No. C3274/73	GI Riser pipe (3") and "Sockets": draw. No. C3349/37	GI Riser pipe (2") and "Sockets": draw. No. C3309/04
Cylinder arrangement	[*] Cylinder, Plunger & Footvalve of Brass: drawing No. A3305	Cylinder, Plunger & Footvalve of Brass: drawing No. A3262	Cylinder, Plunger & Footvalve of Brass: drawing No. A3338	Cylinder, Plunger & Footvalve of Brass: drawing No. A3361
Pumprod arrangement	Pumprods, with Hook & Eye connectors: drawing No. A3247	same as "A" or "D"	same as "A" or "D"	Pumprods with threaded connectors: drawing No. A3350

Explanations:

* The Ø50 mm Cylinder is mostly used for deep or extra deep wells.

Note: This pump type is not recommended for aggressive waters.

Abbreviations:

GI Galvanized Iron
 ES Extractable System
 NES Non Extractable System

Example:

Possible composition of a selected Bush Pump:

Pump stand type	A
Discharge type	B
Rising main pipe	B
Cylinder arrangement	B
Pumprod arrangement	D

For more clarification see the following 2 pages!

Pump head, Pump stand & Handle

(approx. scale = 1 : 10)

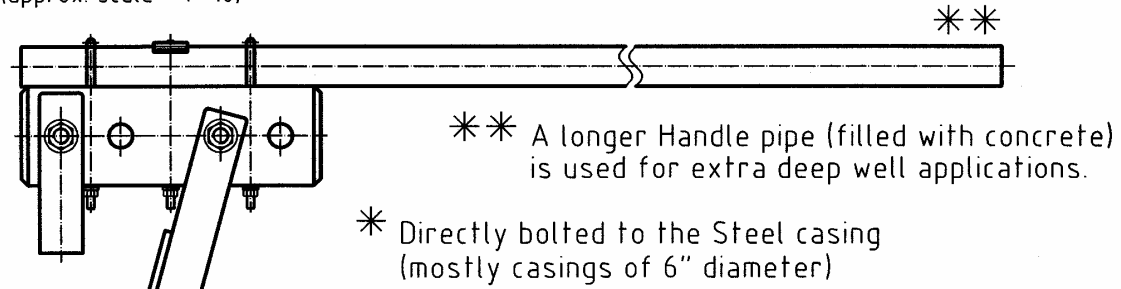

Discharge arrangements

(approx. scale = 1 : 10)

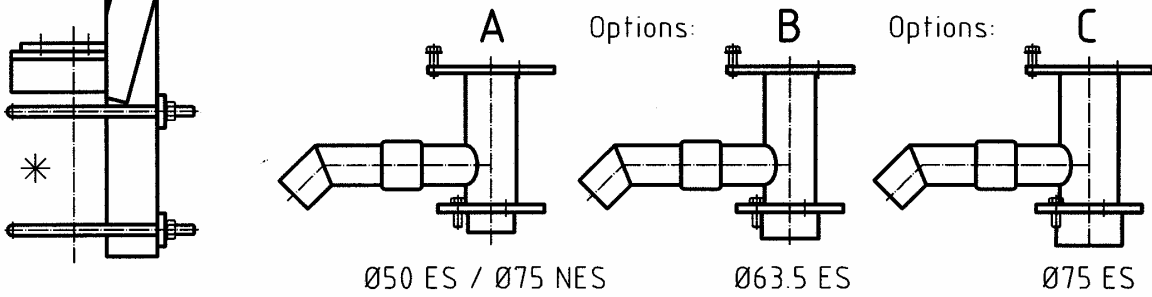

Rising main types

(approx. scale = 1 : 10)

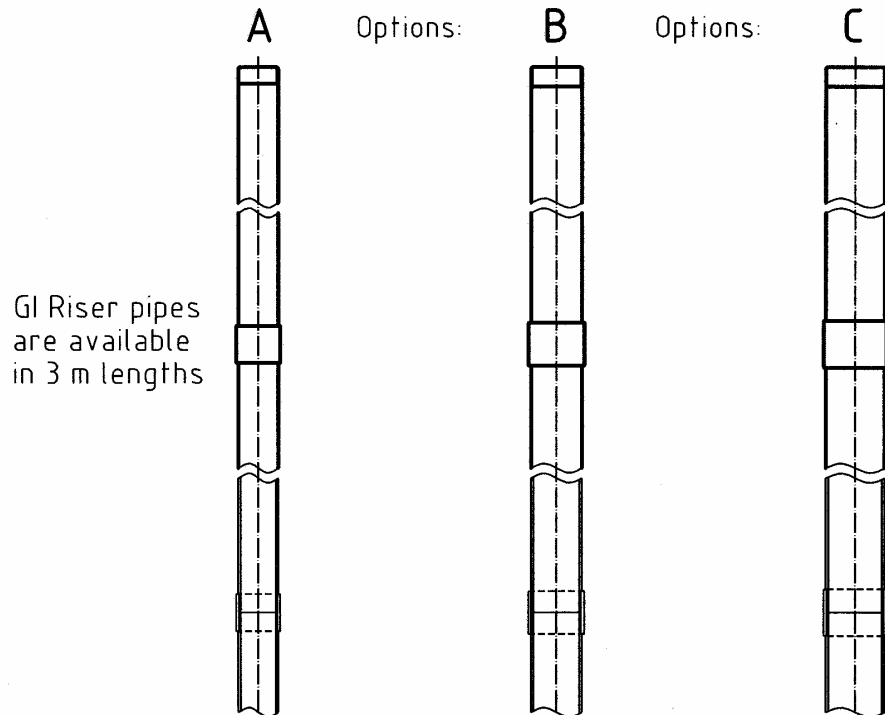

Cylinder arrangements

(approx. scale = 1 : 5)

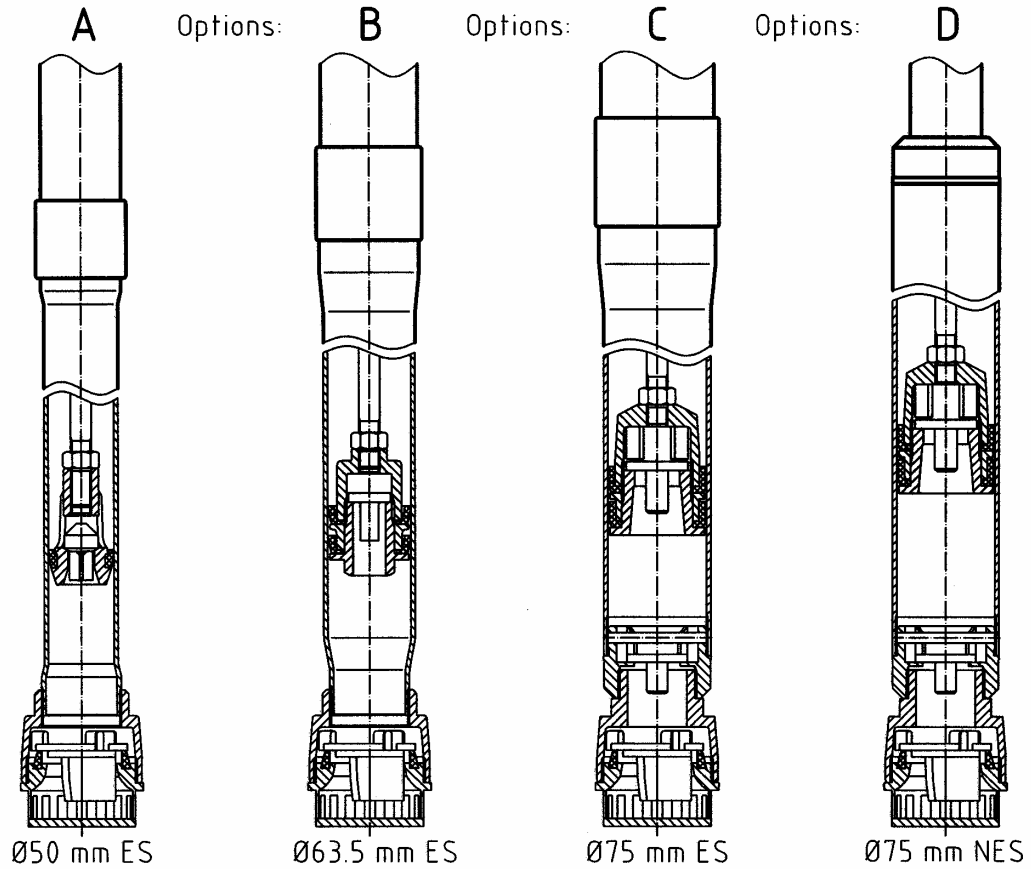

Cylinder A is used for extra deep well applications.

Pumprod arrangements

(approx. scale = 1 : 5)

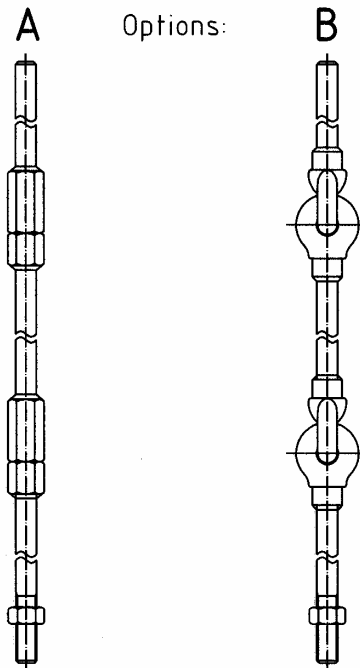

All Pumprods are available in 3 m lengths

5.) Lever operated Pumps for Extra Deep Wells

India Mark II Extra Deep Well Handpump

IS Document IS 13287 : 1992

recommended use between depths of 40 to 90 m.

Supporting documents:

Handpump Specification, available from BIS (see address in Appendix II)

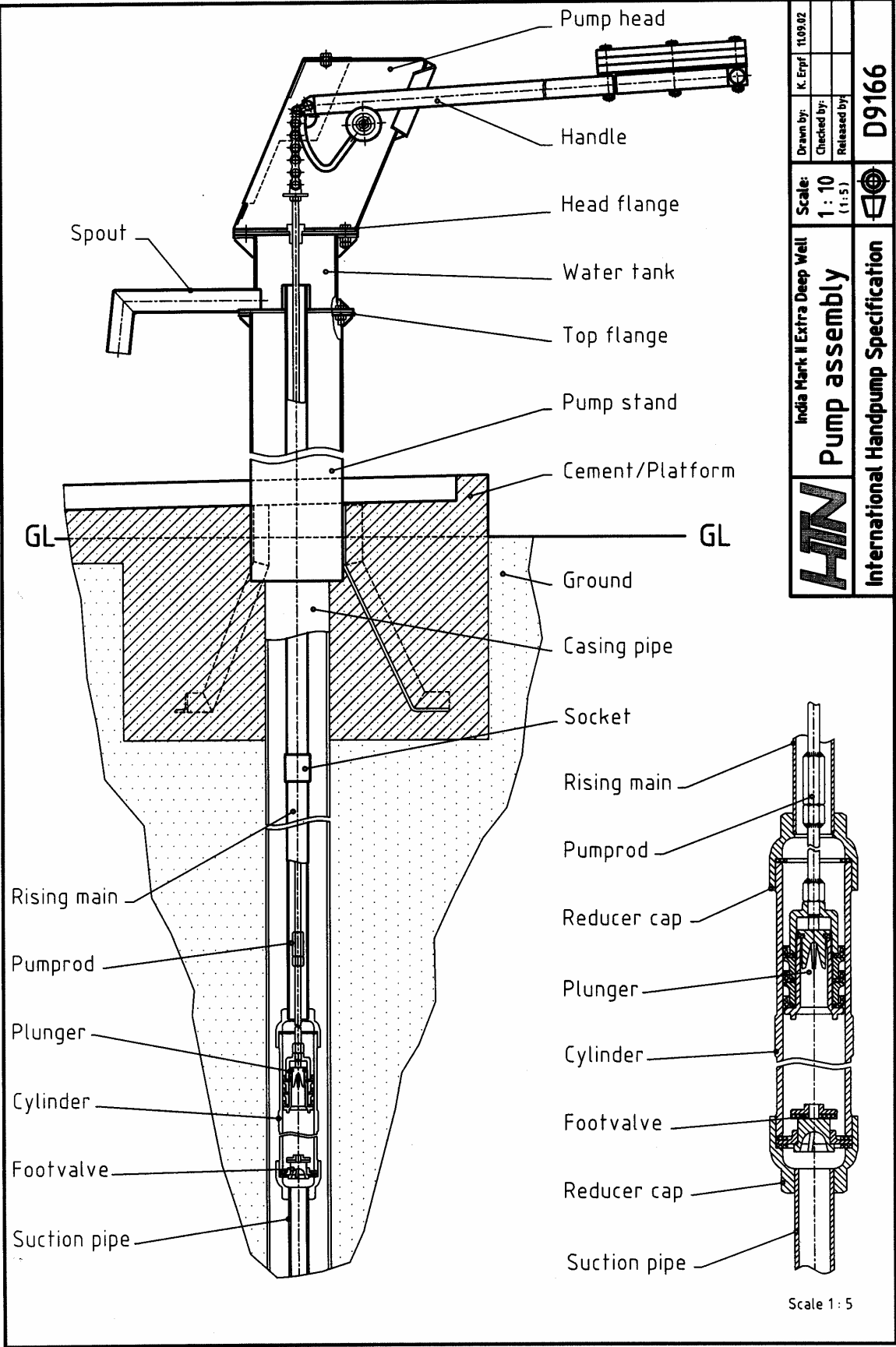

Additional or different components for the India Mark II Extra Deep Well Pump, compared to the “Standard version”:

Extra strong handle with T-bar and holes provided, for fixing additional “Counter weight plates” for balancing of the Pump handle (see pictures below).

Handle assembly for India Mark II Extra Deep Well Pump (approx. scale = 1 : 5)

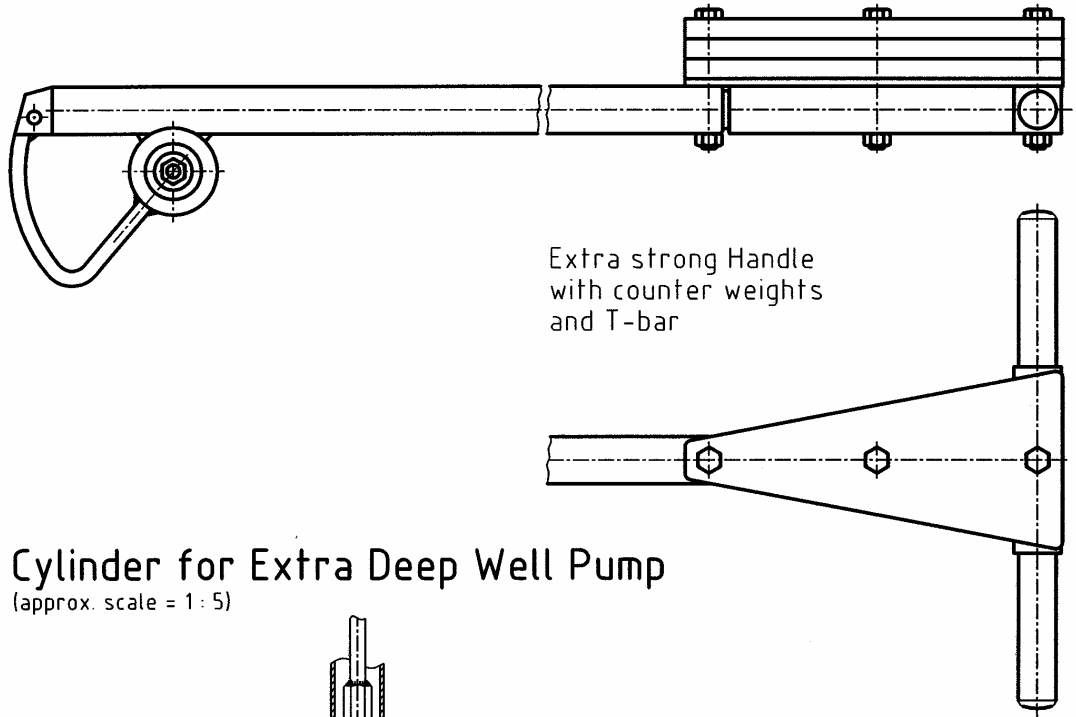

Cylinder for Extra Deep Well Pump (approx. scale = 1 : 5)

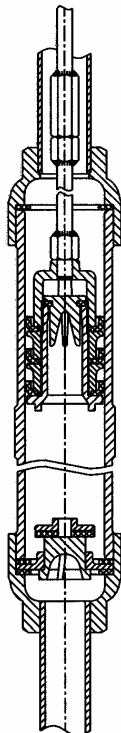

Afridev Deep Well Pump with Bottom Support

SKAT-HTN Document

recommended use between depths of 40 to 80 m.

Supporting documents:

Handpump Specification

Revision 0-2002

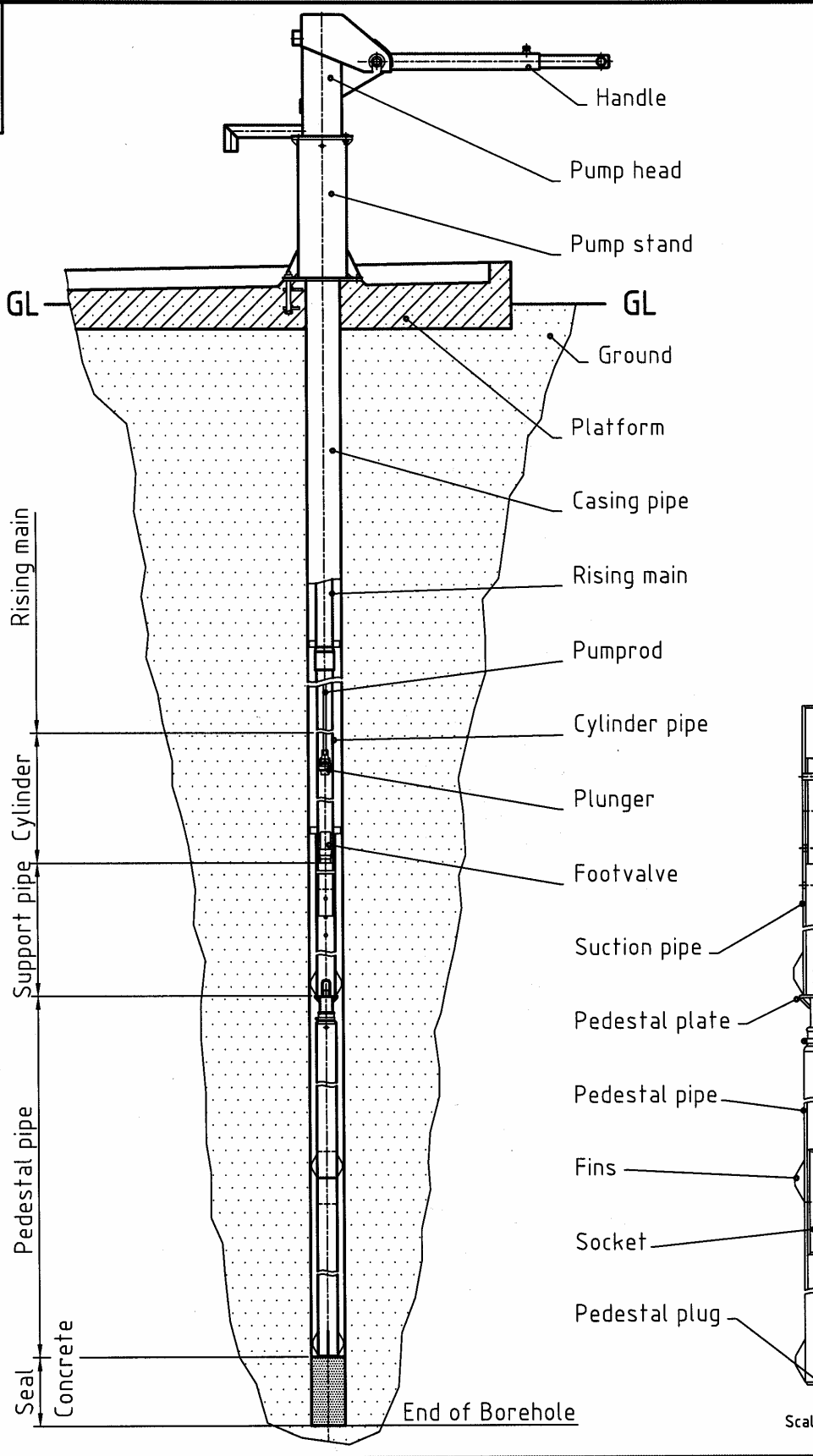

	Afridev Pump with Bottom Support		Scale: 1:20 (1:10)	
	Drawn by: K. Eprf	Checked by:	Released by:	
	Pump assembly			
International Handpump Specification				D9155

Scale 1 : 10

Additional or different components for the “Deep Well” Afridev Handpump, compared to the “Standard version”:

- 1.) Adjustable handle bar (solid) is acting as a counter weight (balancing the Pump handle).
- 2.) Ball bearings for Fulcrum- and Rodhanger assembly.
- 3.) The use of the FRP Pumprod arrangement (A2209) is recommended.
- 4.) For deep well applications exceeding 45 m, the **Bottom Support System** is required (see following drawings).

Cylinder/Rising main assembly

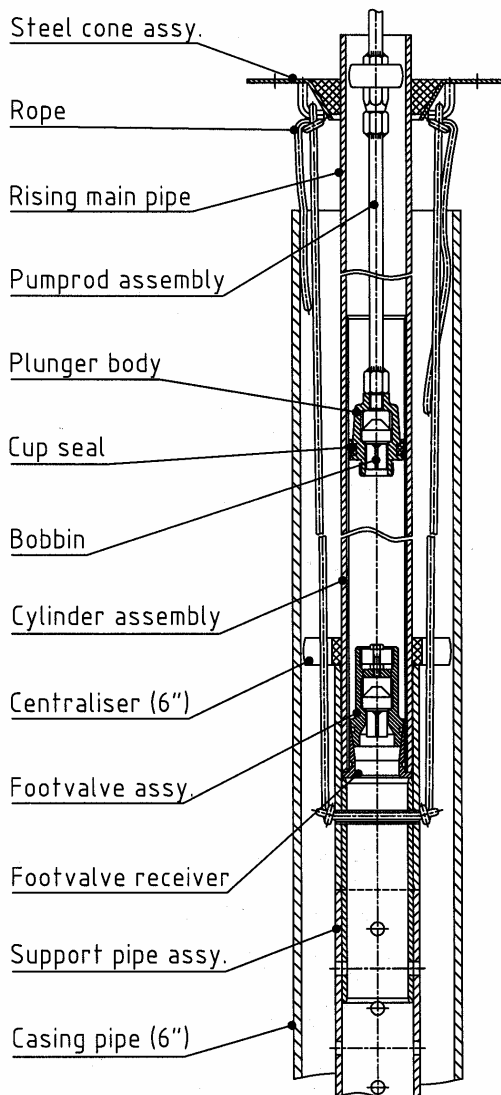

Support pipe assembly

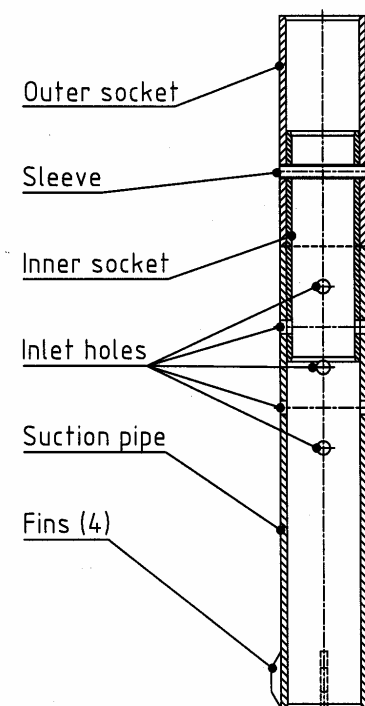

Pedestal pipe assembly

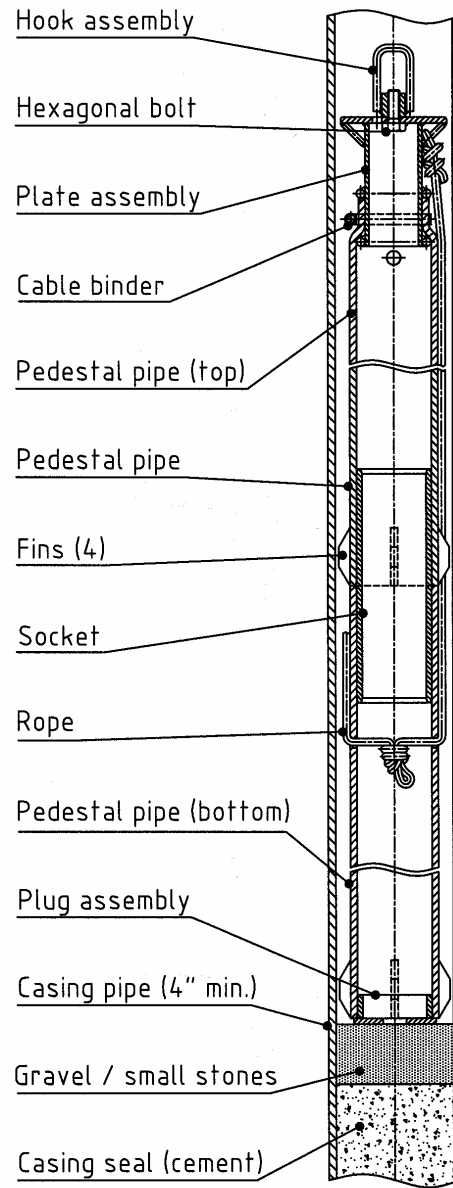

Appendix I

Order Form for Publications

Specifications

Afridev Handpump Specification - Revision 4-2002	(US\$ 50.-/CHF 75.-)	<input type="checkbox"/>
Bomba de acción directa (Maya-Yaku) Especificaciones 0-1993	(free)	<input type="checkbox"/>
MALDA Handpump Specification Revision 1-2000	(US\$ 30.-/CHF 45.-)	<input type="checkbox"/>
Bush Pump Specification Revision 0-1997	(US\$ 50.-/CHF 75.-)	<input type="checkbox"/>
Jibon Deepset Pump Specification Revision 0-1999	(US\$ 30.-/CHF 45.-)	<input type="checkbox"/>
Walimi Deepwell Handpump Specification Revision 0-2002, former SWN-80 Pump (Registration)	(US\$ 50.-/CHF 75.-)	<input type="checkbox"/>
Uganda U3 Modified Deepwell Handpump Specification Revision 0-2001	(US\$ 50.-/CHF 75.-)	<input type="checkbox"/>
Madagascar Rope Pump Specification	in preparation	<input type="checkbox"/>

Manuals

Moulding Guidelines for Rubber Components, Rev. 1-1999	(US\$ 30.-/CHF 45.-)	<input type="checkbox"/>
Afridev Injection Moulding Manual, Revision 1-1999	(US\$ 30.-/CHF 45.-)	<input type="checkbox"/>
Quality Control Guidelines for Afridev Handpump, Rev. 1-2000	(US\$ 30.-/CHF 45.-)	<input type="checkbox"/>
Packaging Guidelines For Afridev, 1992	(free)	<input type="checkbox"/>
Afridev Handpump Installation and Maintenance Manual, 1995	(free)	<input type="checkbox"/>
Pompe manuelle Afridev - manuel d'installation et d'entretien, 1997	(free)	<input type="checkbox"/>
Plastic Laminated Maintenance Card, 1995	(free)	<input type="checkbox"/>
Installation and Maintenance Manual for Malda Handpump	in preparation	<input type="checkbox"/>
Installation and Maintenance Manual for Walimi Handpump	in preparation	<input type="checkbox"/>
Installation and Maintenance Manual for U3M Handpump	in preparation	<input type="checkbox"/>

Working Papers

Choice of technology, 1997	(free)	<input type="checkbox"/>
Uganda's Water Sector Development: Towards Sustainable Systems, 1996	(free)	<input type="checkbox"/>
India Handpump Revolution, 1997	(free)	<input type="checkbox"/>

Case Studies

MALDA Pump – Development of a new Direct Action Pump, 1998	(free)	<input type="checkbox"/>
Bush Pump – The National Standard Handpump of Zimbabwe, 1998	(free)	<input type="checkbox"/>

Appendix II

Addresses for ordering Publications

Address for ordering Indian Standards:

**BIS Bureau of Indian Standards
Manak Bhavan
9 Bahadur Shah Zafar Marg
New Delhi 110 002
India**

**Phone: +91 11 323 0131
Fax: +91 11 323 4062
E-mail: bis@vsnl.com
Homepage: wwwdel.vsnl.net.in/bis.org**

Address for ordering Rope Pump information from Nicaragua:

**Bombas de Mecate
P.O. Box 3352
Los Cedros
Nicaragua**

**Phone: +505 882 39 88
Fax: +505 278 40 45
E-mail: ropepump@ibw.com.ni**

Address for ordering SKAT-HTN Documents:

**skat_consulting
Resource Centre for Development
Vadianstr. 42
CH-9000 St.Gallen
Switzerland**

**Phone: +41 71 228 54 54
Fax: +41 71 228 54 55
E-mail: info@skat.ch
or claudia.schmid@skat.ch
or karl.erpf@skat.ch
home**